

TENNESSEE



**4-H
HORSE
CHAMPIONSHIPS
HANDBOOK**

Tennessee 4-H Horse Championships Handbook

This handbook is to serve as a guide for conducting the Tennessee 4-H Horse Show, Public Speaking, Team and Individual Demonstration Contests and the State 4-H Horse Judging Contest. Extension agents, 4-H Club members, parents, leaders and others involved with these events should read and become familiar with these rules, accept the responsibility to follow these guidelines and, upon signature and submission of entry forms, agree to abide by the rules and regulations. These rules are taken directly and indirectly from breed association rule books and altered to accommodate the Tennessee 4-H Horse Program participants.

Cover by F. Neal Smith, Western Region 4-H Specialist

Table of Contents

Objectives of the 4-H Horse Program	2
Purpose of the Tennessee 4-H Horse Show Program	2
Purpose of the Tennessee 4-H Horse Show Handbook	2
Use of the Name and Emblem of 4-H	2
Eligibility of Participants for the Tennessee 4-H Horse Show	2
General Information: 4-H Members and Horses	4
Forbidden Substances, Methods and Practices	6
Awards	6
Protests	6
State 4-H Horse Show Divisions	7
Southern Regional 4-H Horse Show	7
Trail Classes for All Division	9
Western Division	10
Reining Patterns	16
Speed Division	25
Barrel Racing Pattern	27
Pole Bending Pattern	28
Roping Division	29
Hunter Division	32
Walking and Racking Division	43
Saddleseat/Pleasure Division	64
Miniature Horse Classes	64
Spotted Saddle Horse	70
Dressage	77
Ranch Horse Division	80
Ranch Boxing Pattern	84
Ranch Reining Patterns	91
4-H Horse Project Showmanship & Grooming Scorecard	97
State Communications Contests	100
State Horse Judging Contest	106
State Horse Bowl Contest	107
State Hippology Contest	110

1. Objectives of the 4-H Horse Program

The 4-H Horse Program encourages 4-H members to:

- Develop leadership, initiative, self-reliance, a sense of fair play and other desirable character traits.
- Increase knowledge of all aspects of horse science and management of horses.
- Learn skills of horse management and an understanding of the business and career opportunities of breeding, raising, training, showing and judging horses.
- Experience the pride of owning (if possible) a horse or pony and being responsible for its care.
- Develop an appreciation of horses and horseback riding, which is a healthy form of recreation.
- Promote a great love for animals and a humane attitude toward them.
- Be better prepared for citizenship responsibilities through working in groups and supporting community services and horse activities.

2. Purpose of the Tennessee 4-H Horse Show Program

The purpose of the Tennessee 4-H Horse Show Program is to provide a progressive series of educational opportunities for 4-H members to exhibit their skills at the county, region, state, or regional and national levels. This program allows the 4-H members to participate in activities designed to improve their sense of citizenship, fair play, horse management, character, competitive attitude and self-discipline, while creating an atmosphere for learning and applying life skills.

3. Purpose of the Tennessee 4-H Horse Show Program Handbook

This handbook provides a uniform set of rules and regulations that are intended to standardize 4-H shows throughout Tennessee. It is suggested that these rules be used as a guide for county activities. Counties are encouraged to develop a 4-H horse program to meet local needs and to provide a wide range of educational activities, including a county 4-H horse show. Some classes or divisions in the state 4-H horse show will not be applicable at either the county or region level. If the county or region does not have sufficient interest in a given class or division, it does not have to be held. The list of classes in this program should in no way limit or restrict a county or region program. Each county and/or region is encouraged to include any additional classes that are of a local interest. Only the classes listed in this handbook will be included in the Tennessee 4-H Horse Show.

4. Use of the Name and Emblem of 4-H

- 4.1.** The use of the name and emblem of 4-H is regulated by federal law. This states that only activities or programs under the supervision of UT Extension may use the name and emblem of 4-H.
- 4.2.** Any area (regional), region or state 4-H horse show must have the approval of the state 4-H office.
- 4.3.** Local and county 4-H horse shows must have the approval of the Extension agent.
- 4.4.** Shows or events sponsored by other organizations or individuals that provide separate classes for 4-H members are not permitted to use the name and emblem of 4-H without the approval of the state 4-H office.

5. Eligibility of Participants for the Tennessee 4-H Horse Show

- 5.1.** To be eligible to participate in the Tennessee 4-H Horse Show, 4-H members must have been in the 4th grade on January 1 of the current year. The last year of participation is the end of the calendar year in which the 4-H'er becomes 19 years old or in which the 4-H'er graduates from high school.
- 5.2.** Grade divisions are as follows:

- Junior — Grades 4 and 5
 - Junior High — Grades 6, 7 and 8
 - Senior — Grades 9, 10, 11 and 12
- 5.3. In classes where there is no Junior High division, the Junior class will include grades 4 – 8. The grade level is as of January 1 of the current year.
- 5.4. All 4-H members must complete a TENNESSEE 4-H HORSE ENROLLMENT FORM (F778) for each project horse on or before March 1 of the current year. The form(s) MUST be on file in the county Extension office.
- 5.5. To be eligible for the Tennessee State 4-H Horse Championships, a member must:
- A. Be a bona fide 4-H member.
 - B. Show in at least one class at his/her respective regional 4-H horse show (see rule 5.6).
 - C. Have a current 4-H horse enrollment form dated on or before March 1 and filed with county Extension staff.
 - D. Be showing the member's project horse(s) (see 5.7).
- 5.6. If a member shows in at least one class at his/her regional 4-H horse show, this qualifies the member and ALL the enrolled 4-H project horses of that member for entry at the Tennessee State 4-H Horse Championships. However, only officially enrolled horses that are properly entered in the Tennessee 4-H Horse Championships will be allowed to show. **ADDITIONALLY, ONCE A HORSE IS ENTERED IN A CLASS AT THE TENNESSEE STATE 4-H HORSE CHAMPIONSHIPS, NO CLASSES CAN BE ADDED AND HORSE SUBSTITUTION WILL NOT BE PERMITTED. EXCEPTIONS:**
- A. 4-H members may scratch horses from the various classes.
 - B. Horse substitutions may be made in equitation and showmanship classes.
 - C. If a 4-H member's horse dies, becomes sick or unsound **prior to qualifying at the regional show or before the state show**, the member may substitute another 4-H member's horse or may purchase another horse. A veterinarian's certificate of the death, sickness or unsoundness of the horse must be filed with the Extension agent and brought to the regional or state 4-H horse show.
 - D. Additionally, if a 4-H member becomes sick or injured **prior to competing in a class at the regional show**, that youth may show at the Tennessee State 4-H Horse Show provided a doctor's written certification is presented **at the regional 4-H horse show**.
 - E. In both instances (illness/injury of horse or 4-H member), **proper and timely entry must still be made** for the Tennessee State 4-H Horse Championships.
- 5.7. A 4-H member may be excused from his/her regional show and still participate in the Tennessee State 4-H Horse Championships if:
- A. A letter, signed by both the 4-H member and his/her respective Extension agent, is written stating the reason for the 4-H member's desire to be absent from the regional show.
 - B. This letter is submitted to and approved by the *4-H Animal Science Specialist in Knoxville*.
 - C. The 4-H member, family, leader or Extension agent completes a state entry form along with an entry fee.
- 5.8. The following conditions must be met if the horse is to be eligible as a project animal:
- A. Member and family-owned: The horse is solely and unconditionally owned by the 4-H member or a member of his or her family (parent, brother, sister, grandparent or guardian). Single or combination ownership is permissible. These members must share management duties equally.
- (1) **Horse MAY NOT be shown in the same class twice.**

B. Non-family-owned: The horse is owned by someone other than a member of the immediate family:

- (1) Single or combination ownership is permissible. These members must share management duties equally.
- (2) **Horse MAY NOT be shown in the same class twice.**
- (3) A letter of certification and agreement signed by the owner(s) of the horse and the parent or legal guardian of the 4-H member must be approved by the 4-H leader before the horse can be accepted as a project animal. This letter, along with a picture of the horse, must appear in the record book. The member must have free access to the horse.

5.9. Each Extension agent must certify the eligibility of each member and the horse(s) from his/her county.

5.10. A fee must be submitted for each class in which a horse is entered. A separate entry fee for cattle classes may be assessed.

A. Entry fees are to be submitted **to the County Extension Office** when entry is made.

B. Checks for the entry fees are to be made to the *University of Tennessee*.

C. **Entry fees are non-refundable.**

5.11. State show entry procedures

A. Exhibitors will submit state entry forms and fees to the County Extension office.

B. County agents will then be responsible for submitting the state entries via the online entry system as well as forwarding hard copy forms to the state 4-H animal science specialist.

C. Exhibitors are STRONGLY encouraged to “proof” state entries at the regional show.

6. General Information: 4-H Members and Horses

6.1. It is mandatory that members be polite, be good sports, and be properly attired.

Members are notified that any act of discourtesy or disobedience to the judge, to committee members or other officials on the part of the rider, owner, parents or trainer shall disqualify the horse and the member. A 4-H member MAY NOT receive any physical or electronic assistance in the ring after the youth has entered in the gate.

6.2. **ALL RIDERS (INCLUDING ADULTS) AT 4-H EVENTS AND ACTIVITIES ARE REQUIRED TO WEAR PROPERLY FITTED ASTM/SEI-CERTIFIED HELMETS WITH CHIN STRAPS PROPERLY FASTENED WHILE MOUNTED OR WHILE IN A VEHICLE BEING PULLED BY EQUINE.**

6.3. Dogs of 4-H members, parents, or guests must be on leash at all times and are not allowed in buildings or show rings.

6.4. Cruel or rough handling of horses will not be allowed and may result in elimination at the decision of the judge and/or show committee.

6.5. Horses and ponies must be 3 years old to be shown in any performance class.

6.6. Stallions are ineligible to compete in any 4-H horse show.

6.7. Unruly and unsound horses will be excused from the ring. Determination of unruliness will be left to the judge and/or show committee. Determination of unsoundness will be left to the judge. Unsoundness shall not penalize a rider in equitation classes unless it is sufficiently severe to impair the performance of the horse or is detrimental to the horse's well being.

6.8. The exhibitor must make the choice of showing the animal as a horse or pony. An animal cannot be shown as both a horse and a pony in classes that have separate horse and pony designations. Pony heights for the various divisions are as follows:

- A. Western, Speed Events, Saddleseat, and Spotted Saddle Horse Divisions – 58 inches (14.2 hands) and under
 - B. Hunter Division
 - (1) Small ponies – 50 inches (12.2) hands and under
 - (2) Medium Ponies – more than 50 inches (12.2 hands and not to exceed 54 inches (13.2 hands)
 - (3) Large ponies – more than 54 inches (13.2 hands) and not to exceed 58 inches (14.2 hands)
 - C. Walking/Racking Division – 60 inches (15 hands) and under
- 6.9. All ponies MUST be measured at the regional show in order to show in pony classes at the state show.
- A. If a pony was not shown, and thus was not measured at the regional show, it may be entered into the state show BUT must be measured at the state show prior to pony competition.
 - B. If a "pony" is not measured, it will automatically become a HORSE entry.
 - C. Although an equine is measured as a PONY, it may be shown in HORSE classes **instead of** pony classes.
 - D. A pony may NOT show in BOTH pony and corresponding horse classes.
 - E. A pony MUST be measured every year until the year that the pony is 6 years old. Ponies 6 years old and older will not need to be measured in subsequent years.
 - F. A measurement will only be recorded ONCE for each pony/horse (exception: ponies under 6 years old. See above).
- 6.10. **A member can exhibit only one horse or pony in a class. The same horse MAY NOT be shown in the same class twice. A member MAY NOT enter more than one horse in a class.**
- 6.11. A 4-H member may exhibit a horse in a horse class and a pony in a pony class in the same division (i.e. western pleasure, hunter, barrels, etc.)
- 6.12. PROOF OF A NEGATIVE COGGINS TEST FOR EQUINE INFECTIOUS ANEMIA FROM AN APPROVED LABORATORY WITHIN 12 MONTHS OF THE OPENING DATE OF THE SHOW MUST BE PROVIDED FOR EACH HORSE OR PONY TO BE EXHIBITED.
- 6.13. The **original** certificate showing proof of the negative Coggins test must accompany the horse and be presented before the exhibitor may pick up an entry packet and show. The copy with the horse is the one that will be checked.
- 6.14. Horses that show clinical signs of infections or communicable disease shall not be stalled, shall be denied participation, and must be removed from the grounds.
- 6.15. All exhibitors should check well in advance of the show with their veterinarian for a preventive health program review. A vaccination program should be considered and discussed with the veterinarian.
- 6.16. The age of horses will be determined as of January 1 of the year foaled. A horse becomes a year older on January 1, not on its actual birthday. (Exception: registered Tennessee Walking Horses, Racking Horses and Spotted Saddle Horses foaled in October, November and December may be considered foals of the following year).
- 6.17. Junior Horses – In Western division performance classes, reference to junior horses means 3, 4 and 5 years of age. Junior horses may be shown in a bosal/hackamore or snaffle bit and must be ridden with two hands.
- 6.18. Senior Horses – 6 years of age and older.
- 6.19. Courses, patterns, and/or rules may be altered at the discretion of the Extension staff.
- 6.20. No trainers, parents, or other adults are allowed to ride horses in primary show rings **at any time**.

6.21. No 4-H member will be allowed to ride his/her horse on any concrete or pavement at the state 4-H horse show. Exhibitors MUST lead their horses to the appropriate riding arena or ring. Areas where the 4-H members may mount on pavement or concrete will be designated with signs as a "mount area."

6.22. A 1 minute time limit to enter the ring once a number is called for all entries of all classes will be imposed.

6.23. Hair may be added to the tail of any horse in any division.

7. Forbidden Substances, Methods and Practices

7.1. The administration of any drug affecting the central nervous system (stimulant or depressant) to a horse shown in any 4-H class is strictly prohibited.

7.2. Show management of all 4-H shows or 4-H classes have the right to have horses tested for drugs by a qualified veterinarian. Samples will be submitted to a suitable laboratory for testing, and the results of such tests will be provided to county and state Extension faculty for appropriate action. If the test is positive, the exhibitor will pay all veterinary and laboratory costs and forfeit all and any awards. Otherwise, the protesting party will be liable for such costs.

7.3. The use of irritants (including blisters, ginger or similar soring or pain-inducing substances or devices) that affect the gait, carriage or performance of the horse is forbidden. Horses competing in Walking, Racking, and/or Spotted Saddle Horse classes (excluding Trail) must be inspected by the show DQP prior to competing.

7.4. Horses suspected of being under the influence of any drug, chemical or caustic agent that would alter their natural performance and/or horses having granulation tissue, raw or bleeding sores from old or new scars due to prior mistreatment shall be disqualified from competition.

8. Awards

8.1. Awards will be presented to the top 10 placings in each class. The first place winner will be designated as Grand Champion. The second-place horse will be designated as Reserve Champion. Each entry will receive an appropriate award.

8.2. The judge shall not place any exhibitor regardless of the number of contestants in a class, if the exhibitor is unable to execute the prescribed maneuvers called for to complete the class.

9. Protests

9.1. A protest may be made in writing to the show committee by a leader or an exhibitor, when co-signed by a leader, for any violation of rules other than the judge's decision and pony height after declared by show officials.

9.2. The protest must contain a statement of the act(s) that constitutes the alleged violation and the specific rule(s) allegedly violated.

9.3. The protest must be signed by the protestor(s) and accompanied by a deposit of \$100 cash.

9.4. The protest must be filed within 30 minutes after the infraction in a class.

9.5. The protest (in writing) will be directed to the protest committee and will be decided upon as promptly as the situation permits.

9.6. If the protest is upheld, the \$100 deposit shall be returned; otherwise, it shall be forfeited.

10. State 4-H Horse Show Divisions

10.1. The Tennessee State 4-H Horse Show will have nine separate divisions. They are:

- A. Western
- B. Speed Events
- C. Roping Events
- D. Hunter
- E. Walking/Racking
- F. Saddleseat
- G. Spotted Saddle Horse
- H. Dressage
- I. Ranch Horse

10.2. To maintain division status, the division must have 10 horses competing at the state horse show. If less than 10 horses are exhibited for two consecutive years, the division may be eliminated.

10.3. Horses are eligible to be shown in **NO MORE THAN TWO DIVISIONS** (plus Dressage) at the state 4-H horse show. Miniature horses may show only in miniature showmanship and halter. **A 4-H member may enter only one halter class per division.** County and/or regional 4-H horse shows may allow members to exhibit in more than two divisions. Horses may not be cross-entered between corresponding horse and pony classes.

10.4. Points will be compiled separately for each horse entered. Division champions will be determined based on one horse/one rider. A division winner will be announced for each division. However, in the Walking/Racking Division a separate winner will be announced for walking emphasis and racking emphasis.

A. Tie Breakers

(1) Highest placing in showmanship and grooming class.

(2) Highest placing in equitation class.

10.5. All classes will receive points except team penning and classes for miniatures. Team roping points will be divided between header and heeler equally.

10.6. Each member will be awarded points based on the following sliding scale (State and Southern Regional):

# Horses in Class	Placing	1	2	3	4	5	6	7	8	9	10
1		1									
2		2	1								
3		3	2	1							
4		4	3	2	1						
5		5	4	3	2	1					
6		6	5	4	3	2	1				
7		7	6	5	4	3	2	1			
8		8	7	6	5	4	3	2	1		
9		9	8	7	6	5	4	3	2	1	
10+		10	9	8	7	6	5	4	3	2	1

11. Southern Regional 4-H Horse Show

11.1. Tennessee can send 50 horses to participate in the Southern Regional 4-H Horse Championships.

11.2. All members must pay their own expenses to attend and participate in the Southern Regional 4-H Horse Show. **ALL ENTRIES MUST BE MADE AT THE STATE SHOW.**

11.3. Qualification Procedure

- A. Priority will be given to the top-point-earning senior members, followed by the top-point-earning junior high and junior members. The high-point junior high and junior in each division will be included in the top 50 contestants. **Senior, junior high, and junior members must have earned at least three points to be eligible for consideration for Southern Regional participation.** However, if a full quota is not achieved with the preceding criteria, members with lesser points will be considered, with seniors receiving priority.
- B. Qualification will be based upon seven categories as follows:
- (1) Western Division
 - (2) Speed Events
 - (3) Roping Events
 - (4) Hunter Division
 - (5) Dressage
 - (6) Saddleseat Division
 - (7) Non-Trotting: Walking/Racking Division and Spotted Saddle Horse Division
 - (8) Ranch Division
- C. Members may qualify in only one category. If members qualify in more than one category, they choose which category they will qualify in, thus which horse they will take.
- D. The number of 4-H members qualified from each of these categories will be determined based on the percentage of members exhibiting in each category at the Tennessee 4-H Horse Championships. A member is counted only once in each division.
- E. Members will be ranked by classifications (senior, junior high and junior) within each category from highest- to lowest-point earners to determine qualified members.
- F. If allocations for any of the five categories are not filled by 4-H members desiring to attend Southern Regionals, then additional exhibitors will be taken from each of the other categories.
- G. If allocations still remain, then those members who qualified more than one horse may take a second horse based upon the highest to lowest point-earning members in that group.
- H. Tie Breakers
- (1) Points in most number of classes.
 - (2) Highest placing in showmanship and grooming class.
 - (3) Highest placing in equitation class.
 - (4) Age as of January 1 of the current year – priority to the older member.
- I. ALL YOUTH ARE REQUIRED TO WEAR A PROPERLY FITTED ASTM/SEI-CERTIFIED HELMETS WITH CHIN STRAPS PROPERLY FASTENED WHILE MOUNTED at the Southern Regional horse show.

11.4. Tennessee 4-H members only qualify through this procedure.

11.5. At the Southern Regional 4-H Horse Show, each 4-H'er may enter **one** conformation class, **one** showmanship class, and as many other performance classes as they want.

11.6. There are NO refunds once Southern Regional entries have been submitted by the State Specialist. If a 4-H member's horse dies, becomes sick or unsound before the Southern Regional Show, the member may substitute another 4-H member's horse or may purchase another horse. A veterinarian's certificate of the death, sickness or unsoundness of the horse must be filed with the State Specialist not later than the Monday of the Southern Regional 4-H Horse Show.

Trail Class for All Divisions

1.1. Classes

- A. Class 116, 434, 533, 614, 715, 812 – Junior members
- B. Class 117, 435, 533, 614, 719, 813 – Junior high members
- C. Class 118, 436, 534, 614, 716, 814 – Senior members

1.2. This class will be judged on the performance of the horse over obstacles, with emphasis on manners, response to the rider, and attitude. Horse shall be penalized for any unnecessary delay while approaching the obstacles.

- A. Credit will be given to those horses negotiating the obstacles with style and some degree of speed, providing carefulness is not sacrificed. Credit will be given to horses showing capability of picking their own way through course when obstacles warrant it and willingly responding to rider's cues on more difficult obstacles.
- B. Horses with artificial appearance over obstacles should be penalized, as should exaggerated standing in stirrups and leaning forward over horse's neck by rider.
- C. Six obstacles should be used. Gait between obstacles shall be at the discretion of the judge(s). Failure to follow course shall cause disqualification. Failure to complete obstacle shall not be a disqualification but is to be severely penalized. Three refusals or a maximum of one minute at an obstacle will result in a zero score for that obstacle.
- D. The course shall be reset as original after each horse has worked.
- E. The judge(s) will determine placing.

1.3. The following is a list of obstacles that may be used in the trail class. However, additional obstacles may be required by the judge or show management that will test the horse's ability to perform over trail obstacles.

- A. Opening, passing through and closing a gate. (Changing hands on gate or turning loose of a gate is to be penalized.)
- B. Ride over at least four poles, these being placed a minimum of 15 inches apart. The space between poles is measured. These can be in a straight line, curved, zigzagged, raised or combined with a trot or lope over (trot overs: 3' to 3'6" apart, lope overs: 6 to 7 feet apart).
- C. Ride over wooden bridge. (Suggested minimum width shall be 36 inches wide and at least 6 feet long.)
- D. Water hazard (ditch or small pond). No metal or slick bottom boxes will be used.
- E. Carry object from part of arena to another. (Only objects that reasonably might be carried on a trail ride may be used.)
- F. Back horse through "L"-shaped course:
 - (1) On the ground: 28 inches minimum (space between poles).
 - (2) Elevated: 30 inches minimum (space between poles.)
- G. Put on and remove slicker.
- H. Remove and replace materials from mailbox.
- I. Side pass left or right.
- J. Back through and around three markers set either in a triangle or line.
- K. An obstacle consisting of four logs or rails, each 5 to 6 feet long, laid in a square. Each contestant will enter the square by stepping over log or rail at designated side. When all four feet are inside the square, rider will execute a 360-degree turn (right or left), pause and depart by stepping over log or rail immediately opposite side of entry.

1.4. All trail classes will be judged according to AQHA judging standards.

1.5. See specific division rules for tack and attire requirements:

- A. Western Division: Classes 116, 117, 118
- B. Hunter Division: Classes 434, 435, 436
- C. Walking/Racking Division: Classes 533, 534

- D. Saddleseat Division: Class 612
- E. Spotted Saddle Horse Division: Classes 715, 716
- F. Ranch Horse Division: Classes 812, 813, 814

Western Division

This division is designed for “stock-type horses” (Quarter Horse, Paints, etc.) and will be judged according to those standards and gaits. **All classes in this division (with the exception of Western Dressage) will count towards Western Division high point awards. Western Dressage will not count towards Southern Regional qualifications.** Horses shown in the Western Division MAY NOT be shown in the Ranch Horse Division, **exception: Western Dressage.**

ALL RIDERS ARE REQUIRED TO WEAR PROPERLY FITTED ASTM/SEI-CERTIFIED HELMETS WITH CHIN STRAPS PROPERLY FASTENED AT ALL TIMES WHILE MOUNTED.

1. Gaits

- 1.1 The “walk” is a natural, flat-footed, four-beat gait. The horse must move straight and true at the walk. The walk must be alert, with a stride of reasonable length in keeping with the size of the horse.
- 1.2. The “jog” is a smooth, ground-covering, two-beat diagonal gait. The horse works from one pair of diagonals to the other pair. The jog should be square, balanced and with a straight, forward movement of the feet. Horses walking with their back feet and trotting on the front are not considered performing the required gait. When asked to extend the jog, the horse moves out with the same smooth way of going.
- 1.3. The “lope” is an easy, rhythmical, three-beat gait. Horses moving to the left (counterclockwise) should lope on the left lead. Horses moving to the right (clockwise) should lope on the right lead. Horses traveling at a four-beat gait are not considered to be performing at a proper lope. The horse should lope with a natural stride and appear relaxed and smooth. The horse should be ridden at a speed that is a natural way of going.

2. Attire

The 4-H members must be properly dressed.

- A. Long-sleeved shirt, with collar (stand-up collars are permitted)
- B. Long pants or riding skirt
- C. Belt
- D. ***Exhibitors are REQUIRED to wear properly fitted and fastened ASTM/SEI approved riding helmets at all times while mounted. Cowboy hats are acceptable to wear during halter and showmanship classes ONLY.***
- E. Tie is optional
- F. Boots or hard shoes (no deck or tennis shoes) with a heel and high enough to cover the ankle.
- G. Chaps and spurs are optional (prohibited in halter and showmanship).

3. Tack

- 3.1. In all western classes, horses will be shown in a western saddle. Silver equipment will not count over a good working outfit. Horses 5 years old and younger may be shown in a snaffle bit, hackamore/bosal, curb bit, half-breed or spade bit. Horses 6 years old and older may only be shown in a curb bit, half-breed or spade bit. Chain chin straps are permissible, but must meet the approval of the judge, be at least 1/2 inch in width and lie flat against the jaw

of the horse. **No gag bits or twisted wire mouth pieces (smaller than 3/8") are allowed.**

3.2. Optional equipment

- A. Spurs, not to be used forward of the cinch, except in showmanship and halter classes, where they are prohibited.
- B. Chaps, except in showmanship and halter classes, where they are not allowed.

3.3. Prohibited equipment

- A. Wire chin straps, regardless of how padded or covered.
- B. Any chin strap narrower than 1/2 inch.
- C. Martingales and draw reins.
- D. Nosebands and tie-downs.
- E. Riders **MAY NOT** be secured to the saddle or stirrups in any way, including, but not limited to, the use of velcro on the seat and/or rubber bands on the stirrups.
- F. Protective boots and leg wraps.

4. Western Showmanship

4.1. Classes

- A. Class 101 – Junior members
- B. Class 102 – Junior high members
- C. Class 103 – Senior members

4.2. Horses and ponies are to be shown in hand at halter and will be judged according to the 4-H Horse Project Showmanship Score Card.

5. Western Halter Mares

5.1. Class 104 – Mares (Horse)

5.2. To be shown in hand at halter with natural, roached, pulled, or banded mane. To be judged on conformation, soundness, and condition.

5.3. Each entry will be shown individually at the walk and trot.

5.4. Open to mares of all ages. May be split by age of mares if entries warrant.

6. Western Halter Geldings

6.1. Class 105 – Geldings (Horse)

6.2. To be shown in hand at halter with natural, roached, pulled, or banded mane. To be judged on conformation, soundness, and condition.

6.3. Each entry will be shown individually at the walk and trot.

6.4. Open to geldings of all ages. May be split by age of geldings if entries warrant.

7. Western Halter Ponies

7.1. Class 106

7.2. To be shown in hand at halter with natural, roached, pulled, or banded mane. To be judged on conformation, soundness, and condition.

7.3. Each entry will be shown individually at the walk and trot.

7.4. Open to mares and geldings of all ages. May be split by pony gender and/or age if entries warrant.

8. Western Pleasure – Horse

8.1. Classes

- A. Class 107 – Junior members
- B. Class 108 – Junior high members
- C. Class 109 – Senior members

8.2. To be judged on the performance and conformation of the horse at the discretion of the judge. To be shown at a walk, jog, and lope both ways of the ring on a reasonably loose rein without undue restraint; wrong leads and

excessive speed or slowness at all gaits will be penalized. Horses may be asked to extend the jog one direction of the arena. Horses are to be reversed to the inside (away from the rail). Horses may be required to reverse at the walk or jog, but not at the lope. Horse should stand quietly. Each horse in the finals will be asked to back. Where horses are ridden with a curb bit, one hand only must be used. When one hand is used, it is allowable to use the index finger between the reins.

8.3. Junior horses (3-, 4- and 5-year-olds): a snaffle or hackamore/ bosal may be used and these are to be ridden with two hands.

8.4. Spurs and chaps are optional. Nose bands and/or tie-downs are prohibited.

9. Western Pleasure – Pony

9.1. Class 110

9.2. To be judged on the performance and conformation of the pony at the discretion of the judge. To be shown at a walk, jog, and lope both ways of the ring on a reasonably loose rein without undue restraint; wrong leads and excessive speed or slowness at all gaits will be penalized. Ponies may be asked to extend the jog one direction of the arena. Ponies are to be reversed to the inside (away from the rail). Ponies may be required to reverse at the walk or jog, but not at the lope. Ponies should stand quietly. Each pony in the finals will be asked to back. Where ponies are ridden with a curb bit, one hand only must be used. When one hand is used, it is allowable to use the index finger between the reins.

9.3. In junior ponies, (3-, 4- and 5-year-olds), a snaffle or bosal may be used and these are to be ridden with two hands. A hackamore/bosal or a curb, snaffle, half-breed or spade bit is permissible.

9.4. Spurs and chaps are optional. Nose bands and/or tie-downs are prohibited.

9.5. Open to junior, junior high, and senior members. May be split by age of exhibitor if entries warrant.

10. Western Horsemanship

10.1. Classes

- A. Class 111 – Junior members
- B. Class 112 – Junior high members
- C. Class 113 – Senior members

10.2. General horsemanship

- A. Riders will be judged on seat, hands and their ability to control and show the horse.
- B. Results as shown by performance of the horse are NOT to be considered more important than the method used by the rider.

10.3. Basic position

- A. Rider should sit in the center of the saddle with legs under rider, forming a straight vertical line through ear, center of shoulder, center of hip and back of heel.
- B. Stirrup length should allow heels to be lower than toes, with a slight bend in knee and the toe directly under knee.
- C. Body should always appear comfortable, relaxed and flexible, and back should be nearly flat. Stiff and/or arched lower back should be avoided.
- D. Feet may be placed home in the stirrup, with boot heel touching the stirrup, or may be placed with ball of foot in the stirrup. Riding with toes only in the stirrup will be penalized.

10.4. Hands

- A. Both hands and arms shall be held in a relaxed, easy manner, with the shoulders back and down, and upper arm in a straight line with the

body, the arm holding the reins bent at the elbow, forming a straight line from the elbow to the horse's mouth.

- B. When using a romal, the rider's off-hand shall be around the romal with a least 16 inches of rein between the hands.
- C. Wrists are to be kept straight and relaxed, with thumb on top and fingers closed around the reins. One finger between the reins is permitted when using split reins, but not romal. Some movement of the arm is permissible, but excessive pumping will be penalized.
- D. Reins are to be carried immediately above or slightly in front of the saddle horn. Only one hand is to be used for reining, and hand shall not be changed. Reins should be carried so as to have light contact with the horse's mouth, and at no time shall reins be carried more than a slight hand movement from the horse's mouth. Excessively loose reins will be penalized. In the event a horse (5 years of age or younger) is shown with snaffle bit or hackamore, it is legal for a rider to show with two hands on the reins.

10.5. Position in motion

- A. Rider should sit the trot and not post.
- B. At the lope he/she should remain seated.
- C. Rider should maintain a vertical position at all gaits.
- D. All movements of the horse should be governed by the use of imperceptible aids. Exaggerated shifting of the rider's weight is not desirable. Moving of the lower legs of riders who are short shall not be penalized.

10.6. Mounting and Dismounting

- A. To mount, take up the reins in left hand and place hand on withers.
- B. Grasp stirrup with right hand and insert left foot in stirrup. Placing right hand on horn, mount.
- C. To dismount, rider may either step down or slide down.
- D. The size of the rider must be taken into consideration.

10.7. Class routine

- A. Each rider will perform an individual pattern.
- B. Individual work may be comprised of any of the following:
 - (1) Walk, jog, or lope in a straight line, curve or circle, or any combination of these gaits and patterns, such as a figure eight, etc.
 - (2) Stop.
 - (3) Back.
 - (4) Turn.
 - (5) Sidepass.
 - (6) Simple change of lead through the trot, walk, or halt, in a straight line, figure eight, or any other pattern.
 - (7) Flying change of lead in a straight line, figure eight, or any other pattern.
 - (8) Counter canter.
 - (9) Dismount and mount.
 - (10) Ride without stirrups.
- C. Use of markers helps to standardize patterns and guide riders, but it also increases the degree of difficulty some what. Therefore, marker placement should be carefully planned and indicated in the posted pattern, and the placement in the arena well-supervised.
- D. Show management must post the pattern in ample time for each exhibitor to understand the pattern.
- E. Judging of individual work will begin and end at the indication of the judge. Exhibitors shall leave the arena at the signal, regardless of whether or not they have completed work prescribed.

F. Failure to complete the pattern will not be a disqualification but shall be scored accordingly. The judge will use these individual works to determine the top riders to be called back for rail work, and those selected riders will be required to work on the rail. Horses need not be worked both directions on the rail.

11. Western Reining

11.1. Classes

A. Class 114 – Junior member

B. Class 115 – Senior member

11.2. Any one of the five reining patterns may be used. One of these patterns is to be selected by show management and used by all contestants in the class.

11.3. Each contestant will perform the required pattern individually and separately.

To rein a horse is not only to guide but also to control the horse's every movement. The best reined horse should be willingly guided or controlled with little or no apparent resistance and dictated to completely. All deviations from the exact written pattern must be considered a lack of or temporary loss of control and, therefore, faulted according to severity of deviation. Credit will be given for smoothness, finesse, attitude, quickness and authority in performing the various maneuvers while using controlled speed.

11.4. Scoring will be on the basis of 0-100, with 70 denoting an average performance.

A. The following will result in a no score:

- (1) Failure to complete pattern as written.
- (2) Performing the maneuvers other than in specified order.
- (3) The inclusion of maneuvers not specified.
- (4) Equipment failure that delays completion of pattern.
- (5) Running away or failing to guide where it becomes impossible to discern whether the entry is on pattern.
- (6) Jogging in excess of 1/2 circle or 1/2 the length of the arena while starting a circle, circling or exiting a rollback.
- (7) Overspins of more than 1/4 turn.
- (8) Use of illegal equipment.
- (9) Willful abuse of an animal while in show arena.
- (10) Using reins or romal as a whip.
- (11) More than one finger between reins.
- (12) Changing hands.
- (13) Two hands on reins, (except with junior horses ridden two-handed in a bosal or snaffle bit).
- (14) A rider may untangle excess rein, where excess rein may prevent the rider from continuing the pattern and where the excess can be straightened without affecting the performance of the horse, during hesitations or when settling a horse. Rider's free hand may be used to hold pommel in the normal fashion.

B. The following will result in reduction of five points:

- (1) Spurring in front of cinch.
- (2) Use of free hand to instill fear.
- (3) Holding saddle or touching horse with free hand.
- (4) On walk-in patterns, failure to stop or walk before executing a canter departure.
- (5) On run-in patterns, failure to be in a canter prior to the first marker.

C. The following will result in a reduction of two points:

- (1) Failure to go beyond markers on stops or rollbacks.

- (2) Break of gait (the break of gait penalty will not be applied in the canter departure when starting a circle maneuver for the first 1/4 of a circle).
- (3) Freeze up in spins or rollbacks.
- D. Starting circles or eights-out-of-lead, delayed change of lead or eights-out-of-lead will be judged as follows:
 - (1) Delayed change of lead by one stride will be penalized one-half point.
 - (2) From start to 1/4 circle, deduct one point.
 - (3) From start to 1/2 circle, deduct two points.
 - (4) From start to 3/4 circle, deduct three points.
 - (5) For the complete circle, deduct four points.
- E. Deduct one-half point for starting circle at a jog or exciting rollbacks at a jog up to two strides. Jogging beyond two strides, but less than 1/2 circle or 1/2 the length of the arena, deduct two points.
- F. Deduct one-half point for over or under spinning up to 1/8 of a turn; deduct one point for over or under spinning up to 1/4 of a turn.
- G. Where a change of lead is specified immediately prior to a run to the end of the pen, failure to change lead will be penalized as follows:
 - (1) One point if lead is picked up within two strides.
 - (2) Two points if lead is corrected prior to the stop.
 - (3) Three points if lead is not corrected.
- H. A judge may require any contestant to repeat the performance of any or all of the various parts of the pattern.
- I. Faults against the horse (to be scored accordingly, but not cause disqualification) are as follows:
 - (1) Opening mouth excessively (when wearing bit).
 - (2) Excessive jawing, open mouth or head raising on stop.
 - (3) Breaking gaits.
 - (4) Lack of smooth, straight, stop on haunches (bouncing or sideways stop).
 - (5) Refusing to change leads.
 - (6) Anticipating signals.
 - (7) Stumbling or falling.
 - (8) Backing sideways.
 - (9) Knocking over markers.
- J. Faults against the rider (to be scored accordingly, but not to cause disqualification) are as follows:
 - (1) Losing stirrup or holding on.
 - (2) Any unnecessary aid given by the rider (such as unnecessary talking, petting, spurring, quirting, jerking of reins, etc.).
 - (3) Failure to run circles or eights within the markers is not considered a fault depending on arena conditions and size; however, failure to go beyond markers on roll backs and stops is considered a fault.
- K. Where horses are ridden with a curb bit, only one hand must be used. When one hand is used, it is allowable to use the index finger between the reins. In junior horses (3-, 4- and 5-year-olds), a snaffle or hackamore/bosal may be used and these are ridden with two hands.

Western Reining Pattern 1

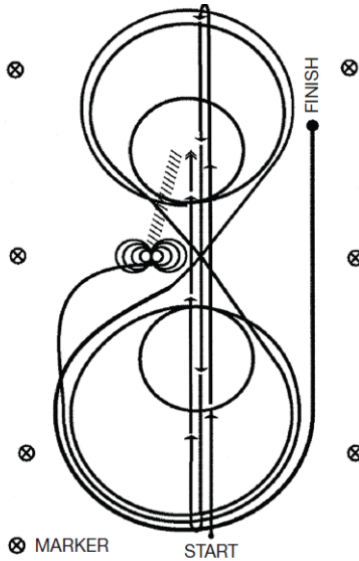

1. Run at speed to the far end of the arena past the end marker and do a left rollback no hesitation.
2. Run to the opposite end of the arena past the end marker and do a right rollback no hesitation.
3. Run past the center marker and do a sliding stop. Back up to center of the arena or at least 10 feet (3 meters). Hesitate.
4. Complete four spins to the right.
5. Complete four and one-quarter spins to the left so the horse is facing the left wall or fence. Hesitate.
6. Beginning on the left lead, complete three circles to the left: the first circle large and fast; the second circle small and slow; the third circle large and fast. Change leads at the center of the arena.
7. Complete three circles to the right: the first circle large and fast; the second circle small and slow; the third circle large and fast. Change leads at the center of the arena.
8. Begin a large fast circle to the left but do not close this circle. Run straight up the right side of the arena past the center marker and do a sliding stop at least 20 feet (6 meters) from the wall or fence. Hesitate to demonstrate the completion of the pattern.

Rider may drop bridle to the designated judge.

Western Reining Pattern 2

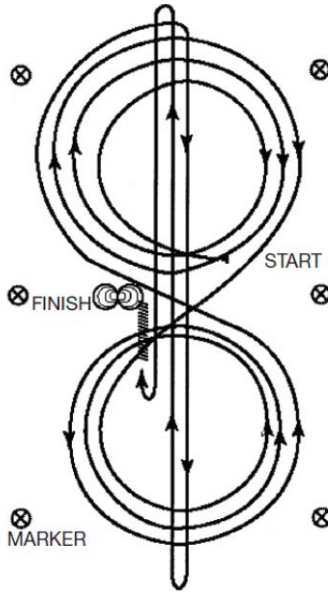

Beginning at the center of the arena facing the left wall or fence:

1. Beginning on the right lead, complete three circles to the right: the first circle small and slow; the next two circles large and fast. Change leads at the center of the arena.
2. Complete three circles to the left: the first circle small and slow; the next two circles large and fast. Change leads at the center of the arena.
3. Continue around previous circle to the right. At the top of the circle, run down the middle to the far end of the arena past the end marker and do a right rollback no hesitation.
4. Run up the middle to the opposite end of the arena past the end marker and do a left rollback no hesitation.
5. Run past the center marker and do a sliding stop. Back up to the center of the arena or at least 10 feet (3 meters). Hesitate.
6. Complete four spins to the right.
7. Complete four spins to the left. Hesitate to demonstrate the completion of the pattern.

Rider may drop bridle to the designated judge.

Western Reining Pattern 3

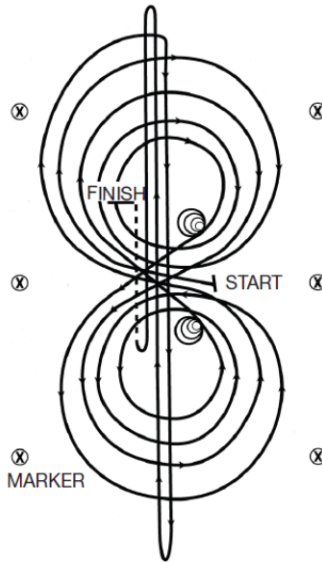

Beginning at the center of the arena facing the left wall or fence:

1. Beginning on the right lead, complete three circles to the right: the first two circles large and fast; the third circle small and slow. Stop at the center of the arena.
2. Complete four spins to the right. Hesitate.
3. Beginning on the left lead, complete three circles to the left: the first two circles large and fast; the third circle small and slow. Stop at the center of the arena.
4. Complete four spins to the left. Hesitate.
5. Beginning on the right lead, run a large fast circle to the right, change leads at the center of the arena, run a large fast circle to the left and change leads at the center of the arena.
6. Continue around previous circle to the right. At the top of the circle, run down the middle to the far end of the arena past the end marker and do a right rollback no hesitation.
7. Run up the middle to the opposite end of the arena past the end marker and do a left rollback no hesitation.
8. Run past the center marker and do a sliding stop. Back up to the center of the arena or at least 10 feet (3 meters). Hesitate to demonstrate completion of the pattern.

Rider may drop bridle to the designated judge.

Western Reining Pattern 4

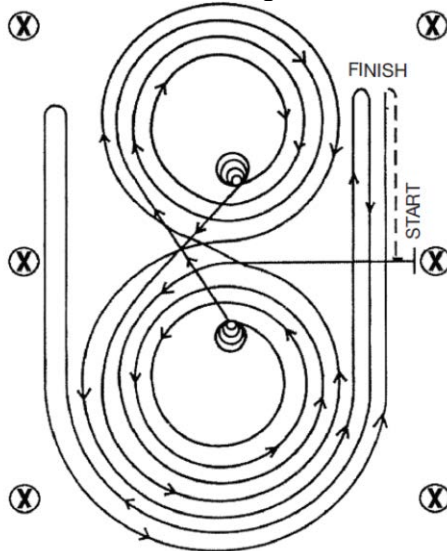

Beginning at the center of the arena facing the left wall or fence:

1. Beginning on the left lead, complete three circles to the left: the first two circles large and fast; the third circle small and slow. Stop at the center of the arena.
2. Complete four spins to the left. Hesitate.
3. Beginning on the right lead, complete three circles to the right: the first two circles large and fast; the third circle small and slow. Stop at the center of the arena.
4. Complete four spins to the right. Hesitate.
5. Beginning on the left lead, run a large fast circle to the left, change leads at the center of the arena, run a large fast circle to the right and change leads at the center of the arena. (Figure 8)
6. Continue around previous circle to the left but do not close this circle. Run up the right side of the arena past the center marker and do a right rollback at least 20 feet (6 meters) from the wall or fence no hesitation.
7. Continue around previous circle but do not close this circle. Run up the left side of the arena past the center marker and do a left rollback at least 20 feet (6 meters) from the wall or fence no hesitation.
8. Continue back around previous circle but do not close this circle. Run up the right side of the arena past the center marker and do a sliding stop at least 20 feet (6 meters) from the wall or fence. Back up at least 10 feet (3 meters). Hesitate to demonstrate completion of the pattern.

Rider may drop bridle to the designated judge.

Western Reining Pattern 5

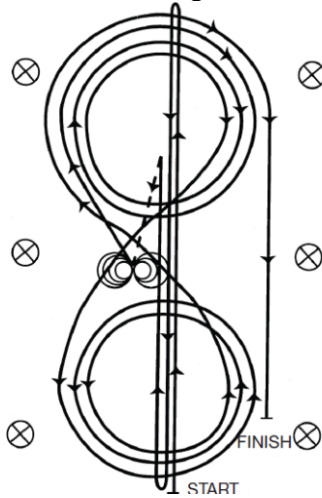

1. Run at speed to the far end of the arena past the end marker and do a left rollback no hesitation.
 2. Run to the opposite end of the arena past the end marker and do a right rollback no hesitation.
 3. Run past the center marker and do a sliding stop. Back up to the center of the arena or at least 10 feet (3 meters). Hesitate.
 4. Complete four spins to the right.
 5. Complete four and one-quarter spins to the left so the horse is facing the left wall or fence. Hesitate.
 6. Beginning on the right lead, complete three circles to the right: the first two circles large and fast; the third circle small and slow. Change leads at the center of the arena.
 7. Complete three circles to the left: the first two circles large and fast; the third circle small and slow. Change leads at the center of the arena.
 8. Begin a large fast circle to the right but do not close this circle. Run straight down the right side of the arena past the center marker and do a sliding stop at least 20 feet (6 meters) from the wall or fence. Hesitate to demonstrate completion of the pattern.
- Rider may drop bridle to the designated judge.

12. Western Dressage

12.1 Class

A. Class 119 Junior and Senior members.

2. Object and General Principles

2.1 The object of Western Dressage is to develop a partnership between a happy equine athlete working in harmony with his rider. A Western Dressage horse achieves this goal by using the principles of classical Dressage training while emphasizing the lightness and harmony with the rider which is a hallmark of a Western Dressage Horse.

3. Appointments

3.1. Personal

Suitable attire would include, but would not be limited to,

- A. Long-sleeved shirt, with collar (stand-up collars are permitted)
- B. Long pants or riding skirt
- C. Belt
- D. **Exhibitors are REQUIRED to wear properly fitted and fastened ASTM/SEI approved riding helmets at all times while mounted.**
- E. Tie is optional
- F. Boots or hard shoes (no deck or tennis shoes) with a heel and high enough to cover the ankle.
- G. Chaps and spurs are optional.

3.2. Tack

- A. In all western classes, horses will be shown in a western saddle. Silver equipment will not count over a good working outfit.
- B. Reins
 - 1. Horses of any age may show in a snaffle, hackamore/bosal for Western Dressage ONLY. Other acceptable bits include a curb bit, half-breed or spade bit.
 - a. Chain chin straps are permissible, but must meet the approval of the judge, be at least 1/2 inch in width and lie flat against the jaw of the horse.
 - b. If a snaffle bit is used, the rider must hold one rein in each hand.
 - c. If the rider is riding with a curb bit he or she has the option of using Romal reins or Spilt reins.
 - 1. If Romal reins are used the rider must hold the rein in one hand with no fingers between the reins. The free

hand must hold the tail and popper, rolled or straight.

2. If the rider uses spilt reins they must hold the rein with one hand, held palm down. The rider is allowed to have one finger only in-between the reins. The tails of reins must fall on the same side as the hand holding the reins.

B. Optional equipment

1. Spurs, not to be used forward of the cinch.
2. Chaps.
3. Whips no longer than 47.2 inches including lash.

C. Prohibited equipment

1. Wire chin straps, regardless of how padded or covered.
2. Any chin strap narrower than 1/2 inch.
3. Martingales and draw reins.
4. Nosebands and tie-downs.
5. Riders **MAY NOT** be secured to the saddle or stirrups in any way, including, but not limited to, the use of velcro on the seat and/or rubber bands on the stirrups.
6. Protective boots and leg wraps.

4. The Gaits and Movements

- 4.1. Halt- Horse should stand attentive, engaged motionless, straight and square with the weight evenly distributed over all four legs. The neck should be raised with the poll as the highest point and the head slightly in front of the vertical. While remaining “on the bit” and maintaining a light soft contact with the rider’s hand, the horse may quietly mouth the bit and should be ready to move off at the slightest indication of the rider.
- 4.2. Working Walk – Four-beat, active energetic walk with resolutely forward-reaching steps and confident stretch to the bit. Head and neck should swing naturally as a result of a relaxed back and free shoulders. The nose must be in front of the vertical. The hind feet should touch the ground into or beyond the prints of the forefeet.
- 4.3. Free Walk – Relaxed walk with unconstrained, forward reaching steps where hind feet touch the ground clearly in front of the footprints of the forefeet. The horse must be relaxed and be allowed complete freedom to lower his head and neck to stretch forward and down and out. The length of stride, rhythm, the relaxation and swing through his back are of great importance.

- 4.4. Working Jog – An energetic, regular, two-beat jog; the horse must go forward with even and elastic steps. The back must be relaxed and the shoulders free, while under the horse. The horse must show proper balance and maintain light contact with the bit. The horse's nose must be in front of the vertical. The working jog may be ridden either posting or sitting.
- 4.5. Working Lope – While maintaining the three beat cadence, the horse must go forward with even and elastic steps. The back must be relaxed and the shoulders free; there is an obvious push from the hindquarters and the hind legs step actively up under the horse. The horse must maintain light contact with the bit and his nose must be in front of the vertical.
- 4.6. Faults of gaits include crookedness, loss of rhythm; tight and tense back with short stiff neck; horse of forehand and/or leaning on the bit; nose consistently behind the vertical; changing tempo; and evasion of contact.

5. Tests

- 5.1. Tests for the current year will be announced at an appropriate time.
- 5.2. Times will be scheduled approximately seven minutes apart.
- 5.3. Rider may begin schooling around the dressage arena when the rider before him/her has received a final salute from the judge and begins to exit the arena.
- 5.4. Upon audible signal (whistle or bell) from the judge, the competitor has 45 seconds to enter the dressage arena.
- 5.5. The dressage tests may be called by someone standing behind the letter E or B, or else the test may be ridden from memory.
 - A. Should a rider go off course, the judge will sound an audible sound.
 - B. The rider should stop and allow the judge to instruct him/her how to proceed. The rider then proceeds from memory or the caller starts calling the test from the point instructed by the judge.
 - C. Being off course constitutes an error. However, if the caller aids the rider in any fashion other than calling the test, the rider is eliminated.
 - D. Errors and points
 - (1) 1st error – 2 points
 - (2) 2nd error – 4 points
 - (3) 3rd error – elimination

6. Elimination

- 6.1. Automatic elimination occurs if the rider fails to enter the dressage arena within 45 seconds of the judge's audible signal.
- 6.2. All four of the horse's feet leave the arena after the test has begun.

6.3. Unauthorized assistance, obvious lameness or use of illegal equipment.

7. Scoring

10 Excellent	5 Sufficient
9 Very Good	4 Insufficient
8 Good	3 Fairly Badly
7 Fairly Good	2 Bad
6 Satisfactory	1 Very Bad
	0 Not performed

8. Schedules

8.1. A schedule denoting the time an exhibitor must perform the dressage class will be available and posted at office at the Tennessee State 4-H Horse Championships.

8.2. An exhibitor may not change his/her scheduled time of performance.

9. Arena

A small or large dressage arena may be used. The letters set around the arena are placed as pictured on the previous page.

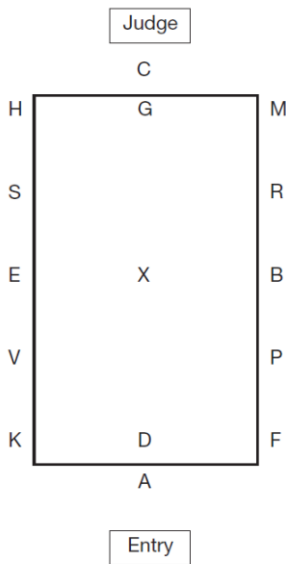

Speed Events Division

Program order for classes and runs **WILL BE STRICTLY ENFORCED**. Exhibitors who miss their runs will not be allowed to run at the end of the class. It is each exhibitor's responsibility to monitor class progression and be at the arena on time. DO NOT rely on the PA system to reach all areas of the show grounds. **ALL RIDERS ARE REQUIRED TO WEAR PROPERLY FITTED ASTM/SEI-CERTIFIED HELMETS WITH CHIN STRAPS PROPERLY FASTENED AT ALL TIMES WHILE MOUNTED.**

1. Attire

- 1.1. The 4-H members must be properly dressed.
- A. Long-sleeved shirt, with collar (stand-up collars are permitted)
 - B. Long pants
 - C. Belt
 - D. Contestants are **REQUIRED** to wear properly fitted and fastened ASTM/SEI approved riding helmets at all times while mounted.
 - E. Boots or hard shoes (no deck or tennis shoes) with a heel and high enough to cover the ankle.
 - F. Chaps and spurs are optional.

2. Tack

- 2.1. In all classes, horses will be shown in a western saddle. Horses may be shown in a snaffle bit, hackamore/bosal, curb bit, half-breed, or spade bit. Chain chin straps are permissible, but must be at least 1/2 inch in width and lie flat against the jaw of the horse.
- 2.2. Optional equipment
- A. Nosebands.
 - B. Martingales and tie-downs (no bare metal or wire may be in contact with horse's head).
 - C. Protective boots and leg wraps.
- 2.3. Prohibited equipment
- A. Wire chin straps, regardless of how padded or covered.
 - B. Any chin strap narrower than 1/2 inch.
 - C. Riders **MAY NOT** be secured to the saddle or stirrups in any way, including, but not limited to, the use of velcro on the seat and/or rubber bands on the stirrups.

3. Barrel Racing

3.1 Classes

- A. Class 201 – Junior members – Horse
- B. Class 202 – Junior high members - Horse

- C. Class 203 – Senior members – Horse
 - D. Class 204 – Junior members – Pony
 - E. Class 205 – Senior members – Pony
- 3.2.** The course must be measured exactly. If the course is too large for the available space, the pattern should be reduced five yards at a time until the pattern fits the arena. Remember to leave adequate space between barrels and any obstacle. The distance from barrel number three to the finish line need not be reduced five yards at a time, if there is sufficient room for the horse to stop. Brightly colored 55-gallon steel drums with both ends in must be used. There shall be no rubber or plastic barrels or barrel pads used.
 - 3.3.** When measuring the area for the barrel course, remember to leave ample room for horses to complete their turns and stop at the finish. It is recommended that there be at least 45 feet from the starting line to the end of the arena, at least 18 feet from barrels one and two to the fence, and 36 feet from barrel three to the end of the arena.
 - 3.4.** Starting line markers or electric timers shall be placed, where possible, against the arena fence. Electric timer or at least two watches shall be used, with the time indicated by the electric timer or average time of the watches used by official timers to be the official time. Barrel racing is a timed event.
 - 3.5.** The contestant is allowed a running start. Timing shall begin as soon as the horse's nose reaches the starting line and will be stopped when the horse's nose passes over the finish line.
 - 3.6.** At a signal from the starter, the contestant will run to barrel number one, pass to the left of it, and complete an approximately 360 degree turn around it; then go to barrel number two, pass to the right of it, and complete a slightly more than 360 degree turn around it; then go to barrel number three, pass to the right of it, and do another approximately 360 degree turn around it; and then sprint to the finish line, passing between barrels number one and two. For example, the contestants will start to barrel number two, turning to left around this barrel, then to barrel number one, turning to the right, then to barrel number three, turning again to the right, followed by the final sprint to the finish line.
 - 3.7.** Knocking over a barrel shall carry a five-second penalty. Failure to follow the course shall cause disqualification. A contestant may touch the barrel with his or her hands in barrel racing. Any contestant who goes on the wrong side of a barrel past the point of the horse's shoulder, runs on the outside of barrel one or two toward the finish line from barrel three, or adds an additional 360-degree turn other than those specified shall be disqualified.

- 3.8. The judge, at his or her discretion, may disqualify a contestant for excessive use of a bat, crop, whip, or rope in front of the cinch.
- 3.9. In the event of a tie, the horse declared the winner in the runoff must re-run the pattern within two seconds of its original time or the runoff must be held again. Penalty time will not apply to the two-second rule but will apply to the final runoff time.
- 3.10. A contestant can not be assisted by anyone inside the arena; such action shall result in disqualification. Once a contestant breaks the “starting line” timer, that contestant MUST continue without a restart.

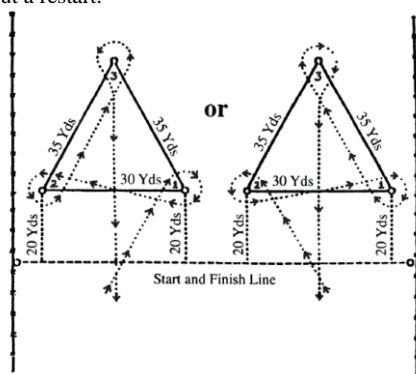

4. Pole Bending

4.1. Classes

- A. Class 206 – Junior members – Horse
- B. Class 207 – Junior high members – Horse
- C. Class 208 – Senior members – Horse
- D. Class 209 – Junior members – Pony
- E. Class 210 – Senior members – Pony

- 4.2. Pole bending is a timed event. Each contestant will begin from a running start, and time shall begin and end as the horse’s nose crosses the line. (A clearly visible starting line shall be provided). An electric timer or at least two watches shall be used, with the time indicated by the electric timer or the average time of the watches used by official timers to be the official time.
- 4.3. The pole bending pattern is to be run around six poles. Poles are to be 21 feet apart, and the first pole is to be 21 feet from the starting line. Poles shall be set on top of the ground, 6 feet in height, with no base more than 14 inches in diameter.
- 4.4. A horse may start either to the right or to the left of the first pole and then run the remainder of the pattern accordingly (see pattern). Any contestant going by a pole on the wrong side as

far as the shoulder point of the horse shall be considered off course, even if the horse is corrected and continues properly.

- 4.5. Knocking over a pole shall carry a five-second penalty. Failure to follow the course shall cause disqualification. A contestant may touch a pole with his or her hand in pole bending.
- 4.6. The judge, at his/her discretion, may disqualify a contestant for excessive use of a bat, crop, whip, or rope in front of the cinch.
- 4.7. In the event of a tie, the horse declared the winner in the runoff must re-run the pattern within two seconds of its original time, or the runoff must be held again. Penalty time will not apply to the two-second rule but will apply to the final runoff time.
- 4.8. A contestant can not be assisted by anyone inside the area; such actions shall result in disqualification. Once a contestant breaks the "starting line" timer, that contestant **MUST** continue without a restart.

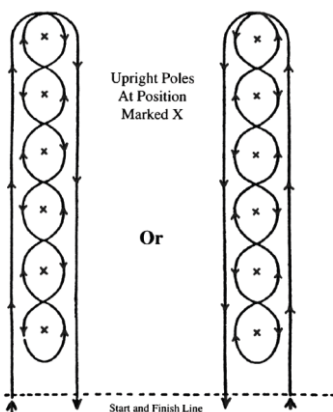

Roping Events Division

1. Attire

- 1.1. The 4-H members must be properly dressed.
 - A. Long-sleeved shirt, with collar (stand-up collars are permitted)
 - B. Long pants
 - C. Belt
 - D. **Contestants are REQUIRED to wear properly fitted and fastened ASTM/SEI approved riding helmets at all times while mounted.**
 - E. Boots or hard shoes (no deck or tennis shoes) with a heel and high enough to cover the ankle.
 - F. Chaps and spurs are optional.

2. Tack

- 2.1. In all classes, horses will be shown in a western saddle. Horses may be shown in a snaffle bit, hackamore/bosal, curb bit, half-breed, or spade bit. Chain chin straps are permissible, but must be at least 1/2 inch in width and lie flat against the jaw of the horse.
- 2.2. Optional equipment
 - A. Nosebands.
 - B. Martingales and tie-downs (no bare metal or wire may be in contact with horse's head).
 - C. Protective boots and leg wraps.
- 2.3. Prohibited equipment
 - A. Wire chin straps, regardless of how padded or covered.
 - B. Any chin strap narrower than 1/2 inch.
 - C. Riders **MAY NOT** be secured to the saddle or stirrups in any way, including, but not limited to, the use of velcro on the seat and/or rubber bands on the stirrups.

3. Breakaway Roping

- 3.1. Classes
 - A. Class 301 – Junior members
 - B. Class 302 – Senior members
- 3.2. Breakaway roping is a timed event and must be completed within one minute or a no time will be given. Common rodeo conditions and standards of calf roping apply in this contest, except the roper does not dismount or tie the calf. The roper must throw the first loop within 30 SECONDS or retire from the arena with a no score.
- 3.3. The horse must start from behind a barrier. The length of the score line will be adjusted to fit arena conditions and shall not exceed one foot per 20 feet of arena length.

- 3.4. A barrier judge will be designated before the contest. If the horse breaks the barrier as a result of starting too soon, the roper will receive a 10-second penalty. If the horse breaks the barrier as a result of failure of the barrier equipment, no penalty will be assessed. If the calf carries part of the barrier with it or if the roper is fouled by the barrier and the roper declares himself/herself immediately, he/she will be given a rerun. Once the calf is roped, no rerun will be given. Decisions of the barrier judge are final.
- 3.5. A regular rope is tied to the saddle horn or swell with a breakable string. Time starts at signal of the barrier flag and stops when the official signals with a flag that the rope breaks away from the saddle as a result of a legal catch.
- 3.6. A legal catch is defined as a loop that goes over the calf's head and draws up on any part of the body causing the rope to break from the saddle horn.
- 3.7. Judges will rule whether a catch is legal and whether the rope breaks away as a result of a legal catch or as a result of the horse or calf stepping on the rope or similar occurrence. Contestant will be given a no time when something other than a legal catch caused the rope to break away.
- 3.8. A piece of white cloth shall be attached to the rope at the saddle horn to signal when the rope breaks away.
- 3.9. There is a one-minute time limit.
- 3.10. Should the roper desire to throw a second loop, a second loop must be built. If a roper misses with two loops, the roper must retire with a no time.
- 3.11. A roper may have assistance in the box.

4. Calf Roping

- 4.1. Class 303 – Junior and senior members
- 4.2. Contest must have two judges – a field judge to flag finish of a run and a barrier judge. Calf roping is a timed event and must be completed within one minute or a no time will be given. The roper must throw the first loop within 30 SECONDS or retire from the arena with a no score.
- 4.3. Contestant must catch calf, dismount, go down the rope, throw the calf by hand, cross and tie any three legs.
- 4.4. If a calf is down when roper reaches it, calf must be raised off of ground (daylight between calf and ground) and rethrown. If roper's hand is on calf when calf falls, calf is considered thrown by hand. Rope must stay on calf until roper gets hand on calf. Tie must be finished with half hitch or "hooley."
- 4.5. Tie must hold for five seconds after roper gives slack to calf (after remounting) and then must be passed on by the field judge. Roper will be disqualified if he/she touches calf after he/she signals the finish of a tie. No person may touch the calf until the field judge evaluates the tie.

- 4.6. Any catch on any part of calf with rope will be considered legal.
- 4.7. A barrier must be used with a minimum of 4 feet from the score line. Score line shall not exceed one foot per 20 feet of arena length.
- 4.8. If barrier is broken in any place other than designated place or if ring does not fall within 8 feet of post, barrier will not be considered broken.
- 4.9. If any part of barrier fails to work and such failure results in disadvantage to roper, roper may request calf over, at discretion of barrier judge, if he/she declares immediately. Once calf is roped, no roper will receive calf over because of equipment failure.
- 4.10. If flag equipment signaling start of time fails to work, roper must run calf over, regardless of event's of first run.
- 4.11. A flag to signal start of time must be put on jerk line in close location to portion of line going around calf's neck.
- 4.12. Barrier equipment must be inspected by the judge before each contestant competes and replaced if faulty.
- 4.13. A 10-second penalty will be added to the roper's time for beating or breaking the barrier.
- 4.14. Calves shall be uniform in height, weight and age. It is recommended that calves not weigh less than 180 pounds. Judges and officials will eliminate any uneven calves. All calves should have been run and tied down at least once before the contest begins.
- 4.15. Calves will either be drawn or gate cut, depending upon available facilities. If a calf drawn for a roper becomes sick or injured, another calf will be drawn by the judges for that roper.
- 4.16. Roper must be ready to rope when indicated by show official or calf will be turned out.
- 4.17. Calves may be roped more than once in a go-round. When so doing, numbers drawn must indicate whether contestant competes in first or subsequent run-through.
- 4.18. The same person must open the gate and tail the calves for all contestants in a go-round.
- 4.19. At the discretion of the judges, inexperienced ropers may ask for assistance in calming a nervous horse in the starting box.
- 4.20. Two loops will be permitted in a limit of one minute. The roper must throw the first loop within 30 SECONDS or retire from the arena with a no score. Should the roper desire to throw a second loop, a second rope must be built. If a roper misses with two loops, the roper must retire with a no time.
- 4.21. Contestant must adjust rope and reins in a manner that will prevent the horse from dragging the calf. If a horse drags a calf, judges may stop the horse and roper may be disqualified.
- 4.22. If a tie comes loose or the calf gets to its feet before the tie has been examined and ruled a fair one, roper will receive a no time.

- 4.23. If a contestant is given the wrong calf, contestant will compete on calf drawn for him/her and time on incorrect calf will be disregarded.
- 4.24. If a calf gets out of the arena, timers will stop the watches when flagman signals and roper will get the same calf back. Roper will be given lap-and-tap start with time expired when calf got out added to this time.
- 4.25. Types of bridles or other equipment used are optional choices of the contestant; however, officials may prohibit use of any equipment they may consider excessively severe.
- 4.26. A roper may have assistance in the box.

5. Team Roping

5.1. Classes

A. Class 304 – Heading

B. Class 305 – Heeling

- 5.2. Team members must be from the same district and may show once as the header and once as the heeler. Although two separate class numbers are shown, only one set of awards will be given.
- 5.3. The headers will start from behind a barrier. Each contestant will be allowed to carry only one rope. Only three loops per team will be allowed. Roping steers without turning loose of the loop will be considered a no catch.
- 5.4. Roper must dally (at least once around saddle horn) to stop steer. No tied ropes allowed.
- 5.5. Time starts when header leaves chute and will be stopped when steer is roped and both horses are facing steer in line with ropes dallied and tight. Horse's front feet must be on the ground and ropers must be mounted when time is stopped. Steer must be standing up when roped by header or heeler. Team roping run must be completed within ONE MINUTE. The roper must throw the first loop within 30 SECONDS or retire from the arena with a no score.
- 5.6. If a heel loop is thrown before the header has dallied and changed the direction of a steer, the teams will be disqualified.
- 5.7. A broken rope or dropped rope will be considered a no time, regardless whatever time has been taken or not.
- 5.8. If a steer is roped by one horn, roper is not allowed to ride up and put rope over other horn or head with his/her hands. If the heeler ropes a front foot or feet in the heel loop, this is an illegal catch. Neither contestant may remove the front foot or feet from the loop by hand. However, should the front foot or feet come out of the heel loop naturally by the time the field judge drops the flag, the time will be counted.
- 5.9. In case the field judge flags out a team that still legally has one or more loops coming, the judge may give the same steer back

lap-and-tap and a 10-second penalty will be assessed for each loop already thrown.

5.10. The following constitute legal catches:

A. Head

- (1) Around both horns.
- (2) Half a head
- (3) Around the neck

B. Heel

- (1) Any heel catch behind both shoulders is legal if rope goes up heels.
- (2) One hind foot receives five-second penalty. (Hondo passes over one horn and loop over the other, catch is illegal. If loop crosses itself [Figure 8] in a head catch, it is illegal).

5.11. A roper may have assistance in the box.

Hunter Division

All classes in this division will be judged by USEF rules and standards for the Hunter and Hunt Seat Equitation divisions. **All classes in this division will count towards Hunter Division high point awards. However, Novice, Intermediate, Green, and Hunter Hack classes will not count towards Southern Regional qualifications.**

DRESSAGE WILL NO LONGER COUNT TOWARD HUNTER DIVISION POINTS.

ALL RIDERS ARE REQUIRED TO WEAR PROPERLY FITTED ASTM/SEI-CERTIFIED HELMETS WITH CHIN STRAPS PROPERLY FASTENED AT ALL TIMES WHILE MOUNTED.

1. Attire

- 1.1. 4-H members should wear hunt coats of a conservative color, breeches (or jodhpurs), boots or jodhpur shoes, and a properly fitted and fastened ASTM/SEI approved riding helmet.
- 1.2. In excessively hot weather, with approval of the judge, hunt coats may be removed.
- 1.3. Exhibitors are **REQUIRED** to wear properly fitted and fastened ASTM/SEI approved riding helmets at all times while mounted.

2. Equipment

- 2.1. In all classes, an English snaffle (no shank), pelham (with two reins), kimberwick and/or a full bridle, all with cavesson nosebands and plain leather brow bands, must be used.
- 2.2. Saddles must be of black and/or brown colors and of the hunting or forward seat type, and may have an insert on the skirt.
- 2.3. Saddle pads to be of the classic style, composition, and color. Style may be either classic or easy-view with additional area designated for exhibitor number.
- 2.4. Optional equipment may consist of the following:
 - A. Spurs of the unrowelled type
 - B. Crops or bats
 - C. Gloves
 - D. English breast plate
 - E. Braiding of mane and/or tail in hunt style
 - F. Standing martingales are optional in Working Hunter and Equitation Over Fences classes. Standing martingales are NOT permitted in Hunter Hack, Hunter Under Saddle, or Equitation on the Flat classes. Running Martingales are prohibited in ALL classes.

G. Boots and leg wraps may be used in Equitation Over Fences classes only.

2.5. Prohibited equipment includes the following:

- A. Draw reins
- B. Rowelled spurs

3. Showmanship and Grooming

3.1. Classes

- A. Class 401 – Junior members
- B. Class 402 – Junior high members
- C. Class 403 – Senior members

3.2. Horses and ponies are to be shown in hand at halter or bridle.

They will be judged according to the 4-H Horse Project Showmanship and Grooming Score Card.

4. Hunter Mares

4.1. Class 404

4.2. Mares to be shown in hand at halter or bridle with natural, roached, pulled, or braided mane. To be judged on conformation, soundness, and condition.

4.3. Each entry will be shown individually at the walk and trot.

4.4. Open to mares of all ages. Class may be divided by age of mares if entries warrant.

5. Hunter Geldings

5.1. Class 405 – Geldings

5.2. Geldings to be shown in hand at halter or bridle with natural, roached, pulled, or braided mane. To be judged on conformation, soundness, and condition.

5.3. Each entry will be shown individually at the walk and trot.

5.4. Open to geldings of all ages. Class may be divided by age of geldings if entries warrant.

6. Hunter Ponies

6.1. Classes

- A. Class 406 – Mares
- B. Class 407 – Geldings

6.2. To be shown in hand at halter or bridle with natural, roached, pulled, or braided mane. To be judged on conformation, soundness, and condition. Each entry will be shown individually at the walk and trot.

6.3. Open to ponies of all ages. Classes may be divided by age of ponies if entries warrant.

7. Hunter Under Saddle

7.1. Classes

- A. Class 408 – Junior members – Horse

- B. Class 409 – Junior High members – Horse
- C. Class 410 – Senior member – Horse
- D. Class 411 – Junior/Senior members – Small/Medium Pony
- E. Class 412 – Junior/Senior members – Large Pony

7.2. A horse/rider combination may show in only ONE Hunter Under Saddle class.

- 7.3. To be shown at walk, trot and canter both ways of the ring on a light contact. The judge may request any or all horses or ponies to hand gallop in groups up to eight horses. Horses or ponies should perform without undue restraint but should be under control at all times.
- 7.4. The horse or pony must back easily and stand quietly.
- 7.5. To be judged 75 percent on manners, performance and way of going; 25 percent on suitability of horse or pony to rider and cleanliness/neatness of rider, horse or pony, and tack.

8. Hunt Seat Equitation – on Flat

8.1. Classes

- A. Class 413 – Junior members
- B. Class 414 – Junior high members
- C. Class 415 – Senior members

8.2. The rider only is being judged. Rider to show horse at a walk, trot, and canter both directions of the ring. Rider will be judged on his/her seat, hands, legs, feet, position, balance, and control of mount. Suitability of horse to rider shall be considered. Rider may be asked to perform any of the individual tests following:

- A. Back up
- B. Gallop and pull up
- C. Perform figure eight at trot, demonstrating change of diagonals. At left diagonal, rider should be sitting the saddle when left front leg is on the ground; at right diagonal, rider should be sitting the saddle when right front leg is on the ground. When circling clockwise, rider should be on left diagonal.
- D. Perform figure eight at canter on correct lead, demonstrating simple change of lead. (This is a change whereby the horse is brought back into a walk or trot and restarted into a canter on the opposite lead). Figure eight to be commenced in center of two circles so that one change of lead is shown.
- E. Riding without stirrups.
- F. Figure eight at canter on correct lead, demonstrating flying change of lead.
- G. Change leads down center of ring, demonstrating simple change of lead.

- H. Execute serpentine at a trot and/or canter on correct lead, half circles off center of imaginary line where correct diagonal or lead change must be shown.
- I. Canter on the counter lead. No more than eight horses may counter canter at one time.
- J. Perform demonstration ride of approximately one minute on own mount. Rider must write down and give to judge beforehand what pattern he/she plans to demonstrate. To be used for close placing of top riders in class.

9. Hunter Hack

9.1. Classes

- A. Class 416 – Junior/Senior members – Horse or Pony – Novice
- B. Class 417 – Junior/Senior members – Pony
- C. Class 418 – Junior members – Horse
- D. Class 419 – Senior members – Horse

9.2. All entries will be required to jump two fences:

- A. Novice: 2'
- B. Pony: Small/Medium – 2', Large – 2'3"
- C. Horse: 2'6"

9.3. A horse/rider combination may enter only ONE hunter hack class.

9.4. To be shown at a walk, trot, and canter at least one direction of the ring. The judge may ask for a hand gallop, but no more than eight entries to gallop at one time.

9.5. Scoring fences shall be done according to Working Hunter rules.

9.6. Class is to be judged 50% on fences and 50% on rail work.

9.7. MARTINGALES ARE PROHIBITED.

9.8. Novice class restricted to horse/rider combinations who are not capable of jumping higher than 2'. **Horse/rider combination may not cross enter into any Handy Hunter class. Horse/rider combination may not cross enter into any Equitation Over Fences or Working Hunter class other than Novice.**

10. Working Hunter

10.1. Classes

- A. Class 420 – Novice Hunter Over Fences
- B. Class 422 – Green Working Hunter Over Fences
- C. Class 423 – Intermediate Hunter Over Fences
- D. Class 425 – Pony Working Hunter Over Fences
- E. Class 428 – Junior Working Hunter Over Fences – Horse
- F. Class 431 – Senior Working Hunter Over Fences – Horse

10.2. Height of Fences

- A. Novice – 2'

- B. Green – 2’ Small/Medium Ponies; 2’3” Large Ponies; 2’6” Horses
- C. Intermediate – 2’ Small/Medium Ponies; 2’3” Large Ponies; 2’6” Horses
- D. Pony – 2’ Small; 2’3” Medium; 2’6” Large
- E. Junior and Senior Horse – 3’
- F. Distances of in-and-outs:
 - (1) Small/medium ponies = 22 feet
 - (2) Large ponies = 22 feet
 - (3) Horses = 24 feet

10.3. A horse/rider combination may show in only ONE working hunter class.

10.4. Scoring Working Hunter Classes

- A. To be judged on manners, way of going, and style of jumping. Horses shall be credited with maintaining an even hunting pace that covers the course with free-flowing strides. Preference will be shown to horses with correct jumping style that meet fences squarely, jumping at the center of fence. Judges shall penalize unsafe jumping and bad form over fence, whether touched or untouched, including twisting. Incorrect leads around the ends of the course or cross-cantering shall be penalized, as well as excessive use of crop. In-and-outs (one or two strides) shall be taken in the correct number of strides or be penalized. Any error that endangers the horse and/or its rider, particularly refusals or knockdowns, shall be heavily penalized.
- B. Scoring shall be on a basis of 0-100, with an approximate breakdown as follows:
 - (1) 90-100 – an excellent performer and good mover that jumps the entire course with cadence, balance and style.
 - (2) 80-89 – a good performer that jumps all fences reasonably well; an excellent performer that commits one or two minor faults.
 - (3) 70-79 – the average, fair mover that makes no serious faults, but lacks the style, cadence and good balance of the scopier horses; the good performer that makes a few minor faults.
 - (4) 60-6 – poor movers that make minor mistakes; fair or average movers that have one or two poor fences but no major faults or disobediences.
 - (5) 50-59 – a horse that commits one major fault, such as a hind knockdown, refusal, trot, cross canter or drops a leg.
 - (6) 30-49 – a horse that commits two or more major faults, including front knockdowns and

refusals, or jumps in a manner that otherwise endangers the horse and/or rider.

- (7) 10-29 – a horse that avoids elimination but jumps in such an unsafe and dangerous manner as to preclude a higher score.

10.5. Elimination

- A. Third refusal, runout, bolting on course, extra circle, showing an obstacle to a horse, or any combination of these.
- B. Jumping an obstacle before it is reset.
- C. Bolting from ring.
- D. Failure to keep proper course.
- E. Jumping an obstacle not included on the course.
- F. Horse and/or rider falling. Horse is considered to have fallen when shoulder and haunch on the same side touch the ground, or the obstacle and the ground.

10.6. General Information

- A. Circling once upon entering the ring and once upon leaving is permissible unless otherwise noted on course diagram.
- B. After jumping the fence and prior to leaving the arena, the horse shall trot a small circle on a loose rein for soundness.
- C. All horses must be serviceably sound. Any horse showing lameness, broken wind or impairment of vision shall be refused an award.
- D. Horses shall not be requested to re-jump the course.
- E. Manners shall be emphasized.
- F. When an obstacle is composed of several elements, any disturbance of these elements will be penalized; however, only a reduction in height of the top element shall be considered a knockdown.
- G. In cases of broken equipment, the rider may either continue without penalty or stop and correct the difficulty and be penalized the same as any loss of forward impulsion.
- H. When an obstacle requires two or more fences (in-and-out), faults committed at each obstacle are considered separately. In case of a refusal or runout at one element, entry may re-jump the previous elements.
- I. The course must be posted at least one hour before scheduled time of class.
- J. Whenever possible, a schooling area should be provided with at least one practice jump.

10.7. Descriptions of Classes

- A. Novice Hunter Over Fences (420) – Open to horse/rider combinations who are not capable of jumping fences higher than 2'. Open to 4-Hers of any age riding horses

or ponies. Suitability to count. Trot changes optional. 6 to 8 fences; no oxers; no in-and-outs. **Horse/rider combination may not cross enter into any Handy Hunter class. Horse/rider combination may not cross enter into any Equitation Over Fences or Hunter Hack class other than Novice.**

- B. Jr./Sr. Green Working Hunter (422) – Open to 4-Hers of any age riding horses or ponies which are in their first two years of showing over fences. Fences 2' for small/medium ponies, 2'3" for large ponies, and 2'6" for horses. 6 to 8 fences; no oxers or in-and-outs. Course will require at least one change of direction. **Horse may not cross enter into any other working or handy hunter class. Horse/rider combination may not cross enter into any Equitation Over Fences class other than Intermediate.**
- C. Intermediate Hunter Over Fences (423) – Open horse/rider combinations who are not capable of jumping higher than 2' (small/medium ponies), 2'3" (large ponies), or 2'6" (horses). Open to 4-Hers of any age riding horses or ponies. Suitability to count. Course will require at least one change of direction. 6 to 8 fences; no in-and-outs. **Horse/rider combination may not cross enter into any Handy Hunter Class. Horse/rider combination may not cross enter into any Equitation Over Fences class other than Intermediate.**
- D. Jr./Sr. Pony Working Hunter (425) – Open to 4-Hers of any age riding ponies. Suitability to count. Fences 2' for small ponies, 2'3" for medium ponies, and 2'6" for large ponies. To be shown over a course of eight jumps. Fences shall simulate obstacles found in the hunting field.
- E. Junior and Senior Working Hunter (428, 431) – Open to riders in their respective age groups riding horses. Fences 3'. To be shown over a course of eight jumps. Fences shall simulate obstacles found in the hunting field.

11. Handy Working Hunters

11.1. Classes

- A. Class 426 – Junior and senior members - Pony
- B. Class 429 – Junior members - Horse
- C. Class 432 – Senior members - Horse

11.2. Fences shall simulate those found in trappy hunting country.

11.3. Horses are required to trot over one fence toward the end of the course and may be asked to lead over one fence.

11.4. Course will consist of eight jumps. Heights of the fences are as follows:

- A. Small ponies not exceeding 50 inches (12.2 hands) – 2'
- B. Medium ponies over 50 inches (12.2 hands) not exceeding 54 inches (13.2 hands) – 2'3"
- B. Large ponies over 54 inches (13.2 hands) not exceeding 58 inches (14.2 hands) – 2'6"
- C. Horses – 3'

11.5. Distances of in-and-outs

- A. Small/medium ponies = 22 feet
- B. Large ponies = 22 feet
- C. Horses = 24 feet

11.6. A horse/rider combination may enter only ONE Handy

Hunter Class. Horse/rider combinations may not cross enter into Novice or Intermediate classes. Horses may not cross enter into Green Working Hunter.

12. Hunt Seat Equitation Over Fences

12.1. Classes

- A. Class 421 – Novice Equitation Over Fences
- B. Class 424 – Intermediate Equitation Over Fences
- C. Class 427 – Jr./Sr. Equitation Over Fences – Pony
- D. Class 430 – Jr. Equitation Over Fences – Horse
- E. Class 433 – Sr. Equitation Over Fences - Horse

12.2. Height of Fences

- A. Novice – 2' Ponies and Horses
- B. Intermediate – 2' Small/Medium Ponies, 2'3" Large Ponies; 2'6" Horses
- C. Jr./Sr. Pony – 2' Small; 2'3" Medium; 2'6" Large
- D. Junior and Senior Horse – 3'

12.3. A horse/rider combination may enter only ONE Equitation Over Fences class.

12.3. The rider only is being judged. Rider will be judged on his/her seat, hands, legs, feet, position, balance and control of mount. Suitability of horses shall be considered. Individual performance shall consist of riding over a course of at least six jumps at the recommended height. Rider shall have the animal under control at all times. Proper use of the hands is very important.

12.4. Class Descriptions

- A. Novice Equitation Over Fences (421) – Open to riders who are not capable of showing over fences higher than 2'. Trot changes are optional. 6 to 8 fences; no oxers; no in and outs. **Horse/rider combination may not cross enter into any Handy Hunter class. Horse/rider combination may not cross enter into any Working Hunter or Hunter Hack class other than Novice.**

- B. Intermediate Equitation Over Fences (424) – Open to riders who are not capable of showing over fences higher than 2' (small/medium ponies), 2'3" (large ponies), or 2'6" (horses). Course will require at least one change of direction. 6 to 8 fences; no in and outs. **Horse/rider combination may not cross enter into any Handy Hunter Class. Horse/rider combination may not cross enter into any Equitation Over Fences class other than Intermediate or into any Working Hunter class other than Intermediate or Green.**
- C. Jr./Sr. Equitation Over Fences – Pony (427) – Open to riders of all ages mounted on ponies. Fences 2' for small ponies, 2'3" for medium ponies, and 2'6" for large ponies.
- D. Junior and Senior – Horse (430, 433) – Open to riders of all ages mounted on horses. Fences 3'.

Walking and Racking Division

Horses may not cross-enter between Walking Horse and Racking Horse classes. Walking and Racking Horses may show together in Showmanship, In Hand, and Trail Classes ONLY. Classes 506-508 and 510-524 are restricted to Walking Horses, while classes 509 and 525-532 are restricted to Racking Horses.

All horses shown in this division must pass inspection with the show's DQP prior to competing. First place winners in all classes must also be inspected at the conclusion of the class. Exception: horses are not required to be inspected before or after competing the Trail classes (classes 533, 534).

Walking Horses may be shown in EITHER Specialty (2-gait) or 3-gait classes. A 4-H member may show both a 2-gait (Specialty) horse and a 3-gait horse. **The same horse may not show in both 2-gait (Specialty) and 3-gait classes.**

ALL RIDERS ARE REQUIRED TO WEAR PROPERLY FITTED ASTM/SEI-CERTIFIED HELMETS WITH CHIN STRAPS PROPERLY FASTENED AT ALL TIMES WHILE MOUNTED.

1. Qualifying Gaits for Walking Horses

1.1. Flat Walk

- A. The flat walk should be true, bold, and four-cornered, with the forelegs moving straight in an elevated arc and should be accompanied by a pronounced and cadenced head motion.
- B. The rear legs should follow through close to the ground, comfortably over striding the front tracks. Stiff-legged front or rear leg motion and an irregular gait, especially when entering the ring, are typical of the movement of a sore horse. The judge must immediately excuse any horse exhibiting this type of motion from the ring.

1.2. Running Walk

- A. The running walk should be the same general motion as the flat walk, but with additional speed.
- B. The horse shall exhibit a smooth, gliding, overstepping, four-cornered gait, with greater stride and accelerated head motion.
- C. The running walk should be a free and easy gait. Horses exhibiting an exaggerated, hesitating way of going, with a tendency to point with the front feet, are not in form. Twisting of the hocks or stiff-legged rear leg motion shall also be considered a deviation from the

true running walk, and a horse exhibiting these ways of going should be penalized.

1.3. Canter

- A. The canter should be smooth and straight on both leads, not walking behind but cantering on both ends with a rolling, rocking chair motion, comfortably in hand.
- B. Exaggerated “pumping” of the horse at the canter is not considered good form.

1.4. General Information

- A. The Walking Horse should move freely in each gait and proceed in a smooth, fluid, rhythmic manner.
- B. At all gaits, the horse should be flexed at the poll with muzzle slightly tucked. Stiff front or rear leg motion; stumbling; bucking knees; lack of rhythmic timing; pointing or favoring a particular leg; the necessity for excessive pumping or bumping of the horse; or any tendency to rack, pace, or otherwise deviate from the true walk are not typical of the breed. The preceding mannerisms are not considered good form and shall be penalized in judging.

2. Shoeing Requirements for Walking Horses

2.1. Country Pleasure (Classes 510, 511, 512, 516)

- A. The shoe must not exceed 3/8 inch in thickness or 3/4 inch in width and must be a stamped (poured or cast) hot or cold rolled steel or aluminum keg shoe.
- B. Poured or cast clips and/or heel caulks are allowed, if poured in the original cast. Welded on clips or caulks are not permitted.
- C. The use of borium is permitted on the toe and/or heels but must not exceed 1 1/2 inches in width at the toe or 1/8 inch in thickness on the heels.
- D. Shoes must be attached only by nails. Bands and adhesives are not permitted.
- E. Lubricants, artificial appliances, boots, pads, and action devices are prohibited.

2.2. Trail Pleasure (Classes 513, 514, 515, 516)

- A. The shoe must not exceed 3/8 inch in thickness or 3/4 inch in width and must be made of hot or cold rolled steel or aluminum shoe. Clips are allowed when drawn from the original steel, or poured.
- C. The use of borium is permitted on the caulks of shoe but must not exceed 7/8 inch in thickness of shoe, caulk, and borium.
- D. Maximum 1 1/2 inch of turn back (measured from front to back of caulk).
- E. Shoes must be attached only by nails. Bands and adhesives are not permitted.

- F. Lubricants, artificial appliances, boots, pads, and action devices are prohibited.
- 2.3. Lite Shod (Classes 517, 518, 519, 523)**
- A. The shoe must not exceed 1/2 inch in thickness or 1 inch in width and must be made of hot or cold rolled steel or aluminum.
 - B. Turnback must not exceed 1 1/2 inches when caulk is measured from front to back.
 - C. The use of borium is permitted on caulks, but the combined thickness of shoe, caulk, and borium must not exceed 1 1/8 inches.
 - D. Clips are optional and may be drawn from the original steel or poured.
 - E. Shoes must be attached only by nails. Bands and adhesives are not permitted.
 - F. Lubricants, artificial appliances, boots, pads, and action devices are prohibited.
- 2.4. Park Pleasure (Classes 520, 521, 522, 523)**
- A. The shoe must not exceed 1/2 inch in thickness or 1 1/2 inches in width.
 - B. Turnback must not exceed 1 5/8 inches when caulk is measured from front to back.
 - C. The use of borium is permitted on caulks, but the combined thickness of shoes, caulk, and borium must not exceed 1 1/8 inches.
 - D. Clips are optional and may be drawn from the original steel or poured.
 - E. Shoes must be attached only by nails. Adhesives are not permitted. Bands may be used provided that they are placed at least 1 inch below the coronet band and are between 1/2 inch and 3/4 inch in width and made of 16 gauge or smaller flexible steel.
 - F. Lubricants, artificial appliances, boots, pads, and action devices are prohibited.
- 2.5. Open Walking Performance (Classes 524)**
- A. The shoe must not exceed 1/2 inch in thickness or 1 1/2 inches in width. The combined thickness of shoe and caulk must not exceed 1 inch.
 - B. Horses shall be shown in pads made of leather, plastic, or a similarly pliant material. Pads must be a minimum of 1/2 inch. Maximum pad (or artificial extension) thickness must not exceed 50% of the natural hoof length.
 - C. Toe length must exceed the height of the heel by 1 inch or more.
 - D. Bands must be placed at least 1 inch below the coronet band and must be between 1/2 inch and 3/4 inch in width and made of 16 gauge or smaller flexible steel.

E. Lubricants that are supplied by DQP are permitted on pasterns after inspection. Lubricants must be applied in the inspection area under the supervision of DQP.

2.6. Showmanship, In Hand, Equitation, Western Pleasure, and Trail

A. Horses may be shown in any legal shoe as described in the rules above.

3. Attire and Tack for Walking Horses

- 3.1. Proper Walking Horse attire must be adhered to at all times.
However, in excessively hot weather and with the approval of the judge, coats may be removed. Formal or semi-formal attire (i.e., tuxedo shirt and bow tie) should not be worn before 6:00 p.m.
- 3.2. Typical Walking Horse equipment and tack should be used at all times. Bit shanks may not exceed 9 1/2 inches in length (English or Western), except in Open Walking Performance, where shank length is unrestricted.
- 3.3. No tape, Velcro, or other non-typical horse show material or substance can be placed/put on any part of the horse while being presented in the show ring. Penalty is disqualification from the class.
- 3.4. See class descriptions for additional requirements/restrictions.
- 3.5. Exhibitors are **REQUIRED to wear properly fitted and fastened ASTM/SEI approved riding helmets at all times while mounted.**

4. Gaits for Racking Horses

- 4.1. The SHOW WALK is a smooth, collected, slow and easy gait. It is a distinctive four-beat gait displaying both style and grace. The horse is alert and mounted well in the bridle.
- 4.2. The SLOW RACK is a relaxed four-beat gait with both style and action, neither a pace nor a trot. The neck should be arched with the head and ears alert. This gait should be straight and square and in form at all times.
- 4.3. The FAST RACK is in the same form as the slow rack, displaying style, speed and action. The fast rack is faster than either of the other gaits, but at no time should the horse sacrifice form for speed.
- 4.4. The TRAIL PLEASURE WALK is a true walk in which the rider and his/her mount are at complete ease. The rein is light and there is no evidence of any strain on the part of horse or rider.
- 4.5. The TRAIL PLEASURE RACK is a true four-beat gait (very smooth). It is recognized as being the ultimate for a pleasure horse, in which ease of riding and comfort are paramount. There is no evidence of strain on the part of the horse or the rider, and the reins are lightly held in two hands. Speed shall not be considered a factor in judging.

- 4.6. In each of the gaits, the horse must be collected and presented well and the rider must be relaxed and smooth in the saddle. **At no time should the horse display a gait with animated hock action.**
- 4.7. The Racking Horse must exhibit good conformation and be free of blemishes and unsoundness, other than healed permanent type scars.
- 4.8. Abusive treatment and/or training techniques to produce an alteration of the gaits shall not be condoned.

5. Shoeing Requirements for Racking Horses

5.1. Flat Shod Classes – Trail Pleasure Racking and Country

Pleasure Racking (Classes 525 – 528)

- A. Flat Shod shall be construed as being hoof-to-shoe with no pad being used for any purpose, which shall include corrective shoeing. Weighted shoes are allowed.
- B. Shoe must not exceed 1/2 inch thickness or 1 1/2 inches in width, with no bare plates or other weight inside the shoe. The caulk must not exceed 3/4 inch and the shoe must not extend more than 1 inch behind the hoof at the toe.
- C. The use of shoeing bands is permitted.
- D. The use of welded clips are prohibited in all flat shod classes. However, clips that are drawn from the shoe itself are allowed.
- E. No additional weights shall be allowed in or on the hoof other than shoe and nails.

5.2. Open Shod Classes – Show Pleasure Racking and Style

Pleasure Racking (Classes 529 – 532)

- A. Open Shod shall be construed as having pads, which can be flat or wedge pads and must be made of leather, plastic, or similarly pliant material.
- B. Weighted shoes are allowed.
- C. Toe length must exceed the height of the heel by 1 inch or more.
- D. Pad thickness (or artificial extension) shall not exceed 50% of natural hoof length.
- E. The shoe shall not exceed 1/2 inch in thickness or 1 1/2 inches in width. Turnback (measured from the inside of the fold) and caulk shall not exceed 1 inch.

6. Tack and Attire for Racking Horses

- 6.1. All tack must be neat and clean and fit the horse correctly. No tape, Velcro, or other non-typical horse show material or substance can be placed/put on any part of the horse while being presented in the show ring. Penalty is disqualification from the class.

6.2. No boots, set tails, or artificial appliances are permitted in any Racking Horse class.

6.3. Bridles

- A. Hackamores, martingales and tie-downs are prohibited.
- B. Bridles should be the type commonly used by Racking Horses, with single reins.
- C. Bit shanks (ring to ring) can be no longer than 9 ½ inches, except in style and open racking where bit length is unrestricted.

6.4. Saddles

- A. Saddles should be the flat English type.
- B. Forward seat saddles are prohibited.
- C. Western saddles are prohibited except in designated Western and/or Country Pleasure classes.

6.5. Braiding should be attached neatly at forelock and mane.

6.6. Dress

- A. Following the tradition of the show ring, it is necessary that the exhibitors be neatly attired for competition.
- B. The exhibitor will wear an English riding habit, with the exception of designated Country Pleasure Racking classes.
- C. All riding attire shall be neat and properly fitted.

D. Exhibitors are REQUIRED to wear properly fitted and fastened ASTM/SEI approved riding helmets at all times while mounted.

6.7. Breast straps may be used and must be free of any imprinting of names or symbols.

7. Showmanship and Grooming (Walking and Racking)

7.1. Classes

- A. Class 501 – Junior members
- B. Class 502 – Senior members

7.2. Horses and ponies are to be shown in hand at bridle or halter at a walk, running walk/slow rack, and pose.

7.3. To be judged according to the 4-H Horse Project Showmanship and Grooming Score Card.

8. Walking and Racking Mares in Hand

8.1. Class 503

8.2. Mares to be shown in hand at bridle or halter.

8.3. To be judged on conformation, soundness, and condition. Each entry to be shown individually at the walk and running walk/slow rack.

8.4. Open to 4-Hers and mares of all ages. May be split by age of mare if entries warrant.

9. Walking and Racking Geldings in Hand

9.1. Class 504

9.2. Geldings to be shown in hand at halter or bridle.

9.3. To be judged on conformation, soundness and, condition. Every entry to be shown individually at the walk and running walk/slow rack.

9.4. Open to 4-Hers and geldings of all ages. May be split by age of gelding if entries warrant.

10. Walking and Racking Ponies in Hand

10.1. Class 505 – Mares and geldings of all ages.

10.2. To be shown in hand at halter or bridle.

10.3. To be judged on conformation, soundness, and condition.

Every entry to be shown individually at the walk and running walk/slow rack.

10.4. Open to 4-Hers of all ages. May be split by gender and/or age of pony if entries warrant.

11. Walking Seat Equitation

11.1. Classes

A. Class 506 – Junior members, Specialty (no canter)

C. Class 507 – Senior members, Specialty (no canter)

D. Class 508 – Junior and Senior members, 3-gait

11.2. General Information

A. Exhibitors are REQUIRED to wear properly fitted and fastened ASTM/SEI approved riding helmets at all times while mounted.

B. Neat English or Western attire is required – a combination of both is not allowed

C. Riders will be judged on seat, hands, and the ability to control and show the horse. Results as shown by performance of the horse are NOT to be considered more important than the method used by the rider.

D. It should be stressed that the required Walking Seat Equitation is a natural, coordinated and comfortable riding position and should in no way be rigid or exaggerated.

E. A rider should convey the impression of effective and easy control, with the general appearance of being able to ride for a considerable length of time with pleasure.

F. To show a horse well, rider should show himself or herself to the best advantage. Ring generalship shall be taken into consideration by the judge. The appearance, presentation and alertness of the rider and his/her mount make the overall picture of utmost importance.

11.3. English Attire and Tack

A. The rider of Walking Seat Equitation is to be judged on his/her skill and form on a horse. The horse and rider

should be groomed to meticulous perfection. The rider should exercise good taste right down to the smallest, most minute detail. The rider is required to choose a neat, well-fitted habit with accompanying accessories within the guidelines based on tradition and present-day customs.

- B. The two- or three-button saddle suit of a conservative color is correct both day and evening. Suggested colors include black, blue, grey, green, beige, or brown, with coordinated accessories. Vests may be worn and may either match or contrast with the habit color. Careful attention should be given the fit of the habit. The coat length should be at least 3 inches below the fingertips when standing. The jodhpurs should be long enough to rest on the rider's boot top and the bottom of the boot heel when mounted. Jodhpur underpasses should always be worn. A moderate fullness is better than a suit that fits too snugly.
- C. **Exhibitors are REQUIRED to wear properly fitted and fastened ASTM/SEI approved riding helmets at all times while mounted.** A four-in hand tie matching or coordinating with the suit color should be worn with a man's style white or pastel shirt. Boots should be of the English type in either calf or patent leather. Gloves should be of the English type in either calf or patent leather. Gloves shall be worn and may match the suit or be off-white. English type spurs (either blunt or small rowel) and a short riding crop are optional.
- D. The semi-formal or tuxedo-type one-button coat suit is suitable to be worn at night only. The acceptable colors are dark blue, brown, grey or black, with collar or lapels of the same color. A dark bow tie, cummerbund, gloves and dark boutonniere complete the outfit.
- E. The rider's hair must be neat and well groomed. Girls with long hair should have it styled so the back number can be seen easily.
- F. Earrings and bracelets, as well as large rings, do not belong in the show ring; neither do flying hair ribbons, corsages and large flowers. Nothing should detract from the genuine beauty of a well-trained horse and skilled rider.
- G. Bridles should be of the type commonly used by Walking Horses, with a single pair of reins. Colored brow bands are appropriate; however, rhinestones, etc., are not acceptable. Clean, well-kept bridles and shining silver bits are far more attractive. Martingales or similar tie-downs are prohibited.

- H. Saddles should be of the flat, English type and of the correct size for the rider. They should be clean and well-kept with white girth and shining irons. Forward seat or Western saddles are prohibited.
 - I. Braids should be neatly attached at foretop and mane. Colors should blend well with rider's habit, brow band and color of horse. Braids should be of the straight plaited variety with no butterflies or other ornamentations.
- 11.4. Western Tack and Attire**
- A. See Western Division for additional information on tack and attire.
 - B. Australian stock saddles are not permitted.
 - C. Exhibitors are REQUIRED to wear properly fitted and fastened ASTM/SEI approved riding helmets at all times while mounted.**
 - D. The horse should wear a western bridle with no cavesson and bits with shanks not to exceed 9 1/2 inches.
 - E. Western tack and attire including boots and long sleeved shirt are mandatory. Chaps and spurs may be worn at the option of the rider.
- 11.5 Tests from Which Judges May Choose**
- A. Enter ring at the flat-walk, turning to right and proceeding in counter clockwise direction. The class shall proceed at least once around the ring at each gait and, on command, reverse and repeat. Riders may reverse mounts either toward or away from the rail. The gesture of stopping, leaning forward in the saddle and feeling of the curb chain is permissible, if necessary, but certainly not desirable and should be avoided. **Riders in class 508 who do not canter/lope will not be placed regardless of number of entries.**
 - B. Entries shall line up on command and any or all riders may be required to execute any test(s) listed.
 - C. Test may be performed either individually or as a group and may be asked for before or after rail work.
 - D. Test elements include the following:
 - (1) Pick up reins – A quick check on muscular control and sensitivity of hands.
 - (2) Backing – Must be required as a check on hands, arms, thighs, knees and lower legs, feet and voice commands.
 - (3) Dismount and mount – To be done quietly and as gracefully as possible.
 - (4) Group performance around ring – To check on maneuverability, ring generalship, etiquette and sportsmanship.

- (5) Individual performance on rail – Any or all gaits and test may be required, including change of canter leads. See rider in motion from both front and rear at all three walking-horse gaits.
- (6) Rider without stirrups – Any or all gaits may be requested.
- (7) Change canter/lope leads down center of ring – Change leads, stopping at each change.
- (8) Figure eight at canter on correct lead – Full stop required on each change of lead. Pattern to begin at center of two circles so as to work lead change.
- (9) Perform demonstration ride of approximately one minute on own mount. Rider must write down and give to judge beforehand what patterns he/she plans to demonstrate. To be used for close placing of top riders in class.

11.6. Mounting and Dismounting

- A. To mount, take up reins in left hand and place hand on withers. Grasp stirrup leather with right hand and insert left foot in stirrup and mount.
- B. To dismount, rider may either step down or slide down.

11.7. English Hand Positioning

- A. The hands should be held in an easy position, waist or elbow high; over pommel, with palms downward and slightly turned toward body; wrist rounded slightly.
- B. The hands should be in unison with the horse's mouth, showing adaptability as well as control. How and where the horse carries its head determines the height the hands are held above the horse's withers.
- C. Hands and wrists should be flexible and not held extremely separated. (From the rider's view, the hands should be in a "V" shape, close enough for thumbs to touch.) The fingers should be closed over reins, firm but not rigid. Pressure between thumb and index fingers to secure ends. Closed (or crossed) reins shall be used, with both hands on the reins, and the bight of the rein should be on the off-side.

11.8. Basic English Position

- A. To obtain proper position, rider should sit comfortably in the middle of the saddle and find his/her center of gravity by sitting with a slight bend at the knees, without use of the stirrups. While in this position, have stirrup leathers adjusted to fit so that irons will be under ball of foot with even pressure on entire width of sole and center of iron.
- B. The foot position will be natural and comfortable if the knee and thigh are rolled inward and the heel is slightly

lower than the toes. From the front or rear view, the lower leg will be held naturally away from the horse, depending on the anatomy of the rider and the size of the horse.

C. The knee should rest against saddle.

11.9. Position in Motion for English Riders

A. The position in motion should be natural, coordinated and graceful, which is attained only with practice.

B. From the side view a straight line can be drawn perpendicular to the ground through the rider's head, neck, shoulder, hip and ankle.

C. The rider's toe should never be any more forward than his/ her knee, thereby keeping his/her center of balance directly above the feet and ankles.

D. Upper arms should fall naturally from the shoulders toward the hip bones, and should be flexible, never clutched to the body, extended forward or spread away from the body.

E. Hands should be in a comfortable waist-level position, depending on how and where the horse carries its head. The use of the hands should be smooth and gradual, without jerking or pumping at any of the gaits, or jerks on the reins parked.

11.10. Basic Western Position

A. Rider should sit in center of saddle with legs under rider forming a straight vertical line through ear, center of shoulder, center of hip and back of heel.

B. Stirrup length should allow heels to be lower than toes, with slight bend in knee and toe directly under knee.

C. Body should always appear comfortable, relaxed and flexible. The back should be nearly flat. Stiff and/or arched lower back should be avoided.

D. Feet may be placed home in the stirrup, with boot heel touching the stirrup, or may be placed with ball of foot in the stirrup. Riding with toes only in stirrup will be penalized.

11.11. Western Hand Positioning

A. Riders are permitted to show with two hands on the reins.

B. Both hands and arms shall be held in a relaxed easy manner, with the shoulders back and down, and upper arm in a straight line with the body.

C. The arm holding the reins should be bent at the elbow, forming a straight line from the elbow to the horse's mouth.

D. When using a romal, the rider's off-hand shall be around the romal with a least 16 inches of rein between the hands.

- E. Wrists are to be kept straight and relaxed, with thumb on top and fingers closed around the reins. One finger between the reins is permitted when using split reins, but not romal.
 - F. Some movement of the arm is permissible, but excessive pumping will be penalized.
 - G. Reins are to be carried immediately above or slightly in front of saddle horn. Only one hand is to be used for reining, and that hand shall not be changed.
 - H. Reins should be carried so as to have light contact with the horse's mouth and at no time shall reins be carried more than a slight hand movement from the horse's mouth.
 - I. Excessively loose reins will be penalized.
- 11.12. Position in Motion for Western Riders**
- A. At the lope, the rider should remain seated.
 - B. Rider should maintain a vertical position at all gaits.
 - C. All movements of horse should be governed by the use of imperceptible aids.
 - D. Exaggerated shifting of the rider's weight is not desirable.
 - E. Moving of the lower legs of riders who are short shall not be penalized.

12. Racking Equitation

12.1. Class 509

- A. Open to 4-Hers of all ages.
- B. May be split by age of rider if entries warrant.

12.2. Class Procedure

- A. Enter ring at the show walk, turning to right and proceeding in counter-clockwise direction.
 - B. The class shall proceed at least once around the ring in each direction at each gait: show walk, slow rack, and fast rack. Riders may reverse mounts either toward or away from the rail.
 - C. The gesture of stopping, leaning forward in the saddle and feeling of the curb chain is permissible, if necessary, but certainly not desirable and should be avoided.
 - D. Entries shall line up on command, and any or all riders may be required to execute any test(s) listed.
- 12.3. Tests may be performed either individually or as a group and may be asked for before or after rail work and may include any of the following:**
- A. Pick up reins – A quick check on muscular control and sensitivity of hands.

- B. Backing – Must be required, as a check on hands, arms, thighs, knees and lower legs, feet and voice commands (four to eight steps).
- C. Dismount and mount – To be done quietly and as gracefully as possible.
- D. Ride without stirrups – Any or all gaits may be requested.
- E. Change gaits down center of ring in straight line.
- F. Walk and/or rack horses in circle or figure eight.
- G. Perform demonstration ride of approximately one minute on own mount. Rider must write out and give to judge beforehand what pattern he/she plans to demonstrate. To be used for close placing of top riders in class.

12.4. General Information

- A. It should be stressed that the required Equitation Racking Seat is a natural, coordinated and comfortable riding position and should in no way be rigid or exaggerated.
- B. A rider should convey the impression of effective and easy control, with the general appearance of being able to ride for a considerable length of time with pleasure.
- C. To show a horse well, the rider should show himself or herself to the best advantage. Ring generalship shall be taken into consideration by the judges. The appearance, presentation and alertness of the rider and his/her mount make the overall picture of utmost importance.
- D. **Exhibitors are REQUIRED to wear properly fitted and fastened ASTM/SEI approved riding helmets at all times while mounted.**

12.5. Mounting and Dismounting

- A. To mount, take up reins in left hand and place hand on withers. Grasp stirrup leather with right hand and insert left foot in stirrup and mount.
- B. To dismount, rider may either step down or slide down.

12.6. Hand Positioning

- A. The hands should be held in an easy position: waist or elbow high, over pommel, with palms downward, slightly turned toward body, with wrist rounded slightly.
- B. The hands should be in unison with the horse's mouth, showing adaptability as well as control. How and where the horse carries its head determines the height the hands are held above the horse's withers.
- C. Hands and wrists should be flexible and not held extremely separated (from the rider's view the hands should be in a "V" shape, close enough for thumbs to touch). The fingers should be closed over reins, firm

but not rigid. Pressure between thumb and index fingers to secure ends.

- D. Closed (or crossed) reins shall be used, with both hands on the reins, and the bight of the rein should be on the off-side.

12.7. Basic Position

- A. To obtain proper position, the rider should sit comfortably in the middle of the saddle and find his/her center of gravity by sitting with a slight bend at the knees, without use of the stirrups. While in this position, have stirrup leathers adjusted to fit, so that irons will be under the ball of the foot with even pressure on entire width of sole and center of iron.
- B. The foot position will be natural and comfortable if the knee and thigh are rolled inward and the heel is slightly lower than the toes.
- C. From the front or rear view, the lower leg will be held naturally away from the horse, depending on the anatomy of the rider and the size of the horse.
- D. Knee should rest against saddle.

12.8. Position in Motion

- A. The position in motion should be natural, coordinated and graceful, which is attained only with practice.
- B. From the side view, a straight line can be drawn perpendicular to the ground through the rider's head, neck, shoulder, hip and ankle.
- C. The rider's toe should never be any more forward than his/ her knee, thereby keeping his/her center of balance directly above the feet and ankles.
- D. Upper arms should fall naturally from the shoulders toward the hip bones and should be flexible, never clutched to the body, extended forward or spread away from the body.
- E. Hands should be in a comfortable waist-level position, depending on how and where the horse carries its head. The use of the hands should be smooth and gradual, without jerking or pumping at any of the gaits, or jerks on the reins when parked.

12.9. Tack

- A. Bridles should be of type commonly used on Racking Horses, with a single pair of reins. Brow bands decorated with rhinestones, etc., do not belong in equitation classes. Clean, well-kept bridles and shining silver bits are far more attractive.
- B. Martingales or similar tie-downs are prohibited. Saddles should be of the saddle-seat type and of the correct size for the rider. Forward seat or western saddles are prohibited.

- C. Boots may not be used.
- D. All tack should be neat and clean, in good condition and fit correctly on the horse.

12.10. Braiding

- A. Neatly attached at forelock and mane.
- B. Color should blend well with rider's habit and brow band.

14. Country Pleasure

13.1. Classes

- A. Class 510 – English Country Pleasure, Junior members, Specialty (no canter)
- B. Class 511 – English Country Pleasure, Senior members, Specialty (no canter)
- C. Class 512 – Western Country Pleasure, Junior and Senior members, Specialty (no canter)
- D. Class 516 – Country and Trail Pleasure (3-gait), Junior and Senior members, Optional English or Western Tack

13.2. This division shall spotlight the smooth and stylish walk in its most basic form combined with a relaxed and willing attitude.

Judging parameters include:

- A. Overall balance between horse and rider
- B. Correct gaits, smoothness, and economy of motion (the ability to cover a lot of ground for an extended period of time)

13.3. The Country Pleasure horse shall break less than 45 degrees with the knees and lack the lift of the shoulders seen in more animated classes.

13.4. The overstride naturally may be shorter in this class but should never appear "trotty" or stiff. The head nod must truly be an up and down nod (never side to side) but may lack some of the depth needed in other classes.

13.5. The Country Pleasure horse must be alert and well-behaved, stand quietly, and back readily.

13.6. Neat English or Western attire is required – a combination of both is not allowed. Ring snaffles are allowed on any age of horse whether shown Western or English.

13.7. Only keg (factory-stamped) shoes are allowed.

13.9. 2-gait Country Pleasure horses are only eligible to show in the following classes: Showmanship and Grooming, In Hand, Walking Seat Equitation (Specialty), English Country Pleasure (Specialty), Western Country Pleasure (Specialty), and Trail.

13.10. 3-gait Country Pleasure horses are only eligible to show in the following classes: Showmanship and Grooming, In Hand, Walking Seat Equitation 3-gait, Country and Trail Pleasure 3-gait, and Trail.

14. Trail Pleasure

14.1. Classes

- A. Class 513 – English Trail Pleasure, Junior members, Specialty (no canter)
 - B. Class 514 – English Trail Pleasure, Senior members, Specialty (no canter)
 - C. Class 515 – Western Trail Pleasure, Junior and Senior members, Specialty (no canter)
 - D. Class 516 – Country and Trail Pleasure (3-gait) Junior and Senior members, Optional English or Western Tack
- 14.2.** A trail pleasure entry should display a true four beat gait at the flat walk and running walk and never have any tendency to trot, rack or pace.
- 14.3.** These gaits will be more pronounced than that of a country pleasure horse. Horses should display a more defined flat walk, and running walk, which may include a longer stride and more pronounced head shake. Although animation is not desirable, the trail pleasure horse may be slightly more animated than the country pleasure horse.
- 14.4.** Neat English or Western attire is required – a combination of both is not allowed. Ring snaffles are allowed on any age of horse whether shown Western or English.
- 14.5.** The Trail Pleasure horse must be alert and well-behaved, stand quietly, and back readily.
- 14.6.** Neat English or Western attire is required – a combination of both is not allowed. Ring snaffles are allowed on any age of horse whether shown Western or English.
- 14.7.** Only keg (factory-stamped) shoes are allowed.
- 14.8.** 2-gait Trail Pleasure horses are only eligible to show in the following classes: Showmanship and Grooming, In Hand, Walking Seat Equitation (Specialty), English Trail Pleasure (Specialty), Western Trail Pleasure (Specialty), and Trail.
- 14.9** 3-gait horses Trail Pleasure horses are only eligible to show in the following classes: Showmanship and Grooming, In Hand, Walking Seat Equitation 3-gait, Country and Trail Pleasure 3-gait, and Trail.

15. Lite Shod

15.1. Classes

- A. Class 517 – English Lite Shod Pleasure, Junior members, Specialty (no canter)
- B. Class 518 – English Lite Shod Pleasure, Senior members, Specialty (no canter)
- C. Class 519 – Western Lite Shod Pleasure, Junior and Senior members, Specialty (no canter)

D. Class 523 – Lite Shod and Park Pleasure, Junior and Senior members, 3-gait, Optional English or Western Tack

- 15.2.** The Lite Shod horse should display elegant and classic beauty while performing the flat walk, running walk, and canter/lope (in 3-gait class) effortlessly. Manners are also paramount in this class. The horse should be “light and airy” on its front feet. It should have a long, gliding overstride that never exhibits a “crampy” way of going. This horse should never show tendencies to pace, trot, or rack. The hind legs should always be in forward motion and should never have vertical hock motion or be “out behind” itself.
- 1.3.** The Lite Shod horse should be high headed and alert but never nervous.
- 15.4.** The Lite Shod horse should display show “presence” while still exhibiting true pleasure qualities.
- 15.5.** Neat English or Western attire is required – a combination of both is not allowed. Ring snaffles are allowed on any age of horse whether shown Western or English.
- 15.6.** All entries will be asked to back individually in the lineup. Any entry that leans back on its haunches and/or drags both front feet instead of picking them up individually must be heavily penalized.
- 15.7.** 2-gait Lite Shod horses are only eligible to show in the following classes: Showmanship and Grooming, In Hand, Walking Seat Equitation (Specialty), English Lite Shod Pleasure (Specialty), Western Lite Shod Pleasure (Specialty), and Trail.
- 15.8.** 3-gait Lite Shod horses are only eligible to show in the following classes: Showmanship and Grooming, In Hand, Walking Seat Equitation 3-gait, Lite Shod and Park Pleasure 3-gait, and Trail.

16. Park Pleasure

16.1. Classes

- A. Class 520 – English Park Pleasure, Junior members, Specialty (no canter)
- B. Class 521 – English Park Pleasure, Senior members, Specialty (no canter)
- C. Class 522 – Western Park Pleasure, Junior and Senior members, Specialty (no canter)
- D. Class 523 – Lite Shod and Park Pleasure, Junior and Senior members, 3-gait, Optional English or Western tack
- 16.2.** The Park Pleasure horse is significantly more animated than the Lite Shod horse, with a more pronounced head shake. This horse should roll out of its shoulders with a natural reach with

its front legs. It should have a long, gliding overstride and be slightly elevated.

- 16.3. The horse should never appear artificial or cramped in its way of going. The Park Pleasure horse should perform the flat walk, running walk, and canter (in 3-gait class) effortlessly. The horse should display a true, four-beat gait and never show any tendency to trot, rack, or pace. Form is never to be sacrificed for speed.
- 16.4. The horse should be high-headed, alert, and a show horse at all times. Manners are paramount.
- 16.5. Neat English or Western attire is required – a combination of both is not allowed. Ring snaffles are allowed on any age of horse whether shown Western or English.
- 16.6. All entries will be asked to back individually in the lineup. Any entry that leans back on its haunches and/or drags both front feet instead of picking them up individually must be heavily penalized.
- 16.7. 2-gait Park Pleasure horses are only eligible to show in the following classes: Showmanship and Grooming, In Hand, Walking Seat Equitation (Specialty), English Park Pleasure (Specialty), Western Park Pleasure (Specialty), and Trail.
- 16.8. 3-gait Park Pleasure horses are only eligible to show in the following classes: Showmanship and Grooming, In Hand, Walking Seat Equitation 3-gait, Lite Shod and Park Pleasure 3-gait, and Trail.

17. Open Walking Performance

17.1. Classes

A. Class 522 – Junior and senior members, Specialty (no canter)

- 17.2. These classes are for **PADDED HORSES** only. Any Flat Shod horse entered will be disqualified.
- 17.3. Horses in this class should move freely in each gait and proceed in a smooth, fluid, rhythmic manner. At all gaits the horse should be flexed at the poll with muzzle slightly tucked.
- 17.4. Horses will not be required to back.
- 17.5. Stiff front or rear leg motion; stumbling; bucking knees; lack of rhythmic timing; pointing or favoring a particular leg; the necessity for excessive bumping of the horse; or any tendency to rack, pace, or otherwise deviate from the true walk are not typical of the breed. The preceding mannerisms are not considered good form and shall be penalized.
- 17.6. All entries should be presented clean, neatly trimmed, braided, and in good flesh, presenting a healthy appearance. Each entry should be outfitted in clean and appropriate English tack. The exhibitor should be neat in appearance, attired in a properly fitted riding habit, and shall conduct himself or herself in a sportsmanlike manner at all times. **Exhibitors are**

REQUIRED to wear properly fitted and fastened ASTM/SEI approved riding helmets at all times while mounted.

- 17.7. A horse that has not performed all required gaits shall not be placed over a horse that has performed the gaits.
- 17.8. Horse **MUST** have pads and action devices (chains or boots). Action devices are optional for park performance.

18. Trail Pleasure Racking

18.1. Classes

- A. Class 525 – Junior members
- B. Class 526 – Senior members

- 18.2. Entries shall be shown with a flat English saddle and English bridle equipped with a curb or any standard racking horse bit. Martingales and tiedowns are prohibited. Riders shall wear neat, clean appropriate English attire including a coat and tie or collar. Spurs, bats, short whips, crops and similar equipment are all optional. **Exhibitors are REQUIRED to wear properly fitted and fastened ASTM/SEI approved riding helmets at all times while mounted.**
- 18.3. Horses and ponies shall be flat shod, hoof-to-shoe (no pads or bands), and shoe shall be made in a manner either conventional or handmade. Use of chains, boots and any other artificial appliances is prohibited.
- 18.4. The Trail Pleasure horse shall not be required or expected to maintain qualities such as a high head or high front leg lift but should be the ultimate of a trail type horse and should show evidence of being collected in his gaits. In no instance will speed be considered a factor in judging. He should be shown on a light but not loose rein.
- 18.5. Horses shown in Trail Pleasure and/or Country Pleasure classes **MAY NOT** also be shown in Show Pleasure and/or Style Pleasure classes.
- 18.6. Horses and ponies are to be shown at the trail pleasure walk, trail pleasure rack and are to be backed. Class to be judged as follows:
- A. 45% trail pleasure walk
 - B. 45% trail pleasure rack
 - C. 10% conformation and manners

19. Country Pleasure Racking

19.1. Classes

- A. Class 527 – Junior members
- B. Class 528 – Senior members

- 19.2. Horses may be shown in either English or Western appointments. (See section 6 for description of English appointments and Western Division for description of Western appointments.) A combination of both English and Western

appointments is not permitted. **Exhibitors are REQUIRED to wear properly fitted and fastened ASTM/SEI approved riding helmets at all times while mounted.**

- 19.3. The Country Pleasure horse shall be shown with a light rein; both horse and rider must be relaxed and comfortable. He shall not be required to maintain a high head but should be alert in the bridle. He shall not be required to maintain a high front leg lift but should exhibit a smooth stride behind.
- 19.4. To be shown at the show walk, slow rack, and fast rack. Any indication of strain on the part of horse or rider at any gait shall be penalized. Will be required to back at the direction of the judge.
- 19.5. Horses shown in Country Pleasure and/or Trail Pleasure classes MAY NOT also be shown in Show Pleasure and/or Style Pleasure classes.
- 19.6. Class to be judged as follows:
 - A. 30% show walk
 - B. 30% slow rack
 - C. 30% fast rack
 - D. 10% conformation

20. Show Pleasure Racking

- 20.1. Classes
 - A. Class 529 – Junior members
 - B. Class 530 – Senior members
- 20.2. Entries shall be shown with a flat English saddle and English bridle equipped with a curb or any standard racking horse bit. Martingales and tiedowns are prohibited.
- 20.3. A show pleasure horse shall be dependable and pleasurable to ride. In the execution of its three gaits, the Show Pleasure horse should exhibit smoothness of ride required of the true natural Racking Horse, exhibiting a higher head and more animation than the Trail Pleasure or Country Pleasure horse. Front lift must not exceed the height of level and is generally accepted as having lift somewhat less than the Style Pleasure horse. A Show Pleasure horse should be shown on a light but not loose rein; both horse and rider must be relaxed and comfortable. Any indication of strain on the part of the horse or rider at any gait should be penalized.
- 20.4. To be shown at the show walk, slow rack, and fast rack.
- 20.5. To be judged as follows:
 - A. 30% show walk
 - B. 30% slow rack.
 - C. 30% fast rack.
 - D. 10% conformation.

21. Style Pleasure Racking

- 21.1. Classes

- A. Class 531 – Junior members
 - B. Class 532 – Senior members
- 21.2.** Entries shall be shown with a flat English saddle and English bridle equipped with a curb or any standard racking horse bit. Martingales and tie-downs are prohibited. Riders shall wear neat, clean appropriate English attire, including a coat and tie or collar. Spurs, bits, short whips, crops and similar equipment are all optional. **Exhibitors are REQUIRED to wear properly fitted and fastened ASTM/SEI approved riding helmets at all times while mounted.**
- 21.3.** The Style Pleasure horse shall be dependable and pleasurable to ride and shown on a light but not loose rein. The horse shall be more reasonably mounted in the bridle than the Show Pleasure horse, displaying style over animation. The front lift must not exceed the height of level but is generally accepted to have more lift than the Show Pleasure horse, with a longer striding back end.
- 21.4.** To be shown at the show walk and style pleasure rack. Both horse and rider must be relaxed and comfortable, exhibiting a smooth ride. Any indication of strain on the part of horse or rider at any gait should be penalized.
- 21.5.** To be judged as follows:
- A. 45% show walk
 - B. 45% style pleasure rack
 - C. 10% conformation.

Saddleseat/Pleasure Type Division

This division is designed for Saddleseat or “pleasure type” horses and will be judged according to USEF rules and standards. Horses and riders in this division are to be turned out in traditional Saddleseat attire (see USEF rules for specific guidelines). Exception: In Hunter Pleasure, Hunt Seat Equitation, Stock Seat Equitation, and Western Pleasure classes, attire traditional for the discipline is required. Proper attire must be maintained at all times. However, in excessively hot weather, with the approval of the judge, coats may be removed.

ALL RIDERS ARE REQUIRED TO WEAR PROPERLY FITTED ASTM/SEI-CERTIFIED HELMETS WITH CHIN STRAPS PROPERLY FASTENED AT ALL TIMES WHILE MOUNTED.

Horses shown in this division should conform to breed-specific requirements for shoeing. Horses that appear labored or forced in their movement shall be penalized in all classes. The use of chains, rollers, stretchers, shackles, or similar devices while on the competition grounds is strictly prohibited.

1. Saddleseat Showmanship and Grooming

- 1.1. Class 601 – Junior and senior members
- 1.2. Horse and ponies are to be shown in hand at halter or bridle at a walk, trot, and pose.
- 1.3. To be judged according to 4-H Horse Project Showmanship and Grooming Scorecard.

2. Saddleseat Mares in Hand

- 2.1. Class 602
- 2.2. Mares to be shown in hand, at halter or bridle.
- 2.3. To be judged on conformation, soundness, and condition.
- 2.4. Each entry will be shown individually at the walk and trot.
- 2.5. Open to 4-Hers in all grades showing horse or pony mares of all ages.

3. Saddleseat Geldings in Hand

- 3.1. Class 603
- 3.2. Geldings to be shown in hand at halter or bridle.
- 3.3. To be judged on conformation, soundness, and condition.
- 3.4. Each entry will be shown individually at the walk and trot.
- 3.5. Open to 4-Hers in all grades showing horse or pony geldings of all ages.

4. Miniature Horse Showmanship and Halter

- 4.1. Classes

- A. Class 604 – Miniature Showmanship – Junior and Senior members
 - B. Class 605 – Miniature Halter Mares and Geldings – All ages - Junior and Senior members
- 4.2. These are non-point-earning classes. **Miniatures MAY NOT show in ANY other classes at the Tennessee 4-H Horse Championships.**

5. Saddleseat Equitation

- 5.1. Class 606 – Junior and senior members
- 5.2. The rider only is being judged.
- 5.3. Rider to show horses at a walk, trot, and canter both ways of the ring.
- 5.4. Rider will be judged on his/her seat, hands, legs, feet, position, balance, and control of mount.
- 5.5. Suitability of horse to rider shall be considered.
- 5.6. Rider should maintain a seat that is thoroughly efficient and in balance with the horse for riding at any gait. Rider should convey the impression of effective and easy control.
- 5.7. Riders may be asked to back their horses or perform any of the individual tests which follow:
 - A. Address the reins (pick up reins).
 - B. Back up for not more than eight steps.
 - C. Perform on rail.
 - D. Perform around ring.
 - E. Execute figure-eight at trot, demonstrating change of diagonal. Unless specified, it may be started either facing the center or away from the center. If started facing the center, it must be commenced from a halt.
 - (1) At left diagonal, rider should be sitting the saddle when left front leg is on ground.
 - (2) At right diagonal, rider should be sitting saddle when right front leg is on the ground.
 - (3) When circling clockwise, rider should be on left diagonal.
 - (4) When circling counterclockwise, rider should be on right diagonal.
 - F. Execute figure-eight at canter on correct lead, demonstrating simple change of lead. (This is a change whereby the horse is brought back into a walk and restarted into a canter on the opposite lead.) Unless specified, it may be started either facing the center or away from the center. If started facing the center, it must be commenced from a halt. Figure-eight commenced in center of two circles so that one lead change is shown.
 - G. Execute serpentine at a trot and/or canter on correct lead, demonstrating simple change of lead. Administer a

series of left and right half circles off-center of imaginary line where correct diagonal or lead must be shown.

- H. Change leads down center to ring or on the rail, demonstrating simple change of lead. Judge to specify exact lead changes to be executed as well as to specify the beginning lead.
- I. Ride without stirrups for a brief period of time. No more than one minute at the trotting phase.

6. Bridle Path Hack

- 6.1.** Class 607 – Junior and senior members riding horses or ponies
- 6.2.** Horses must be shown in either a single curb, double bridle, or pelham. Junior horses (5 yrs. of age and younger) may be shown in a snaffle. Martingales and tiedowns are prohibited. Spurs and/or a whip or crop are optional at the rider's discretion.
- 6.3.** Horses will be shown at a walk, trot, extended trot, and canter both ways of the ring. Horses are required to hand gallop in at least one direction. Horses may be reversed by turning either towards or away from the rail. Only a safe number (maximum of 8) horses should hand gallop at a time.
- 6.4.** All horses should stand quietly and back readily.
- 6.5.** Horses should display a quiet, willing nature and good manners conducive to a pleasurable ride in the country.

7. English Pleasure

- 7.1.** Class 608 – Junior or senior members riding horses or ponies
- 7.2.** Horse may be shown in a snaffle, pelham, single curb, or double bridle. Light contact must be maintained at all gaits. Martingales and tiedowns are prohibited. Spurs and/or a whip or crop are optional at the rider's discretion.
- 7.3.** It is imperative that the horse give the distinct appearance of being a pleasure to ride and display a pleasurable attitude. All gaits must be performed with willingness, obvious ease, cadence, balance, and smoothness.
- 7.4.** Horses are to be shown at a walk, trot, and canter both ways of the ring. Horses should stand quietly and back readily.
 - A. Walk: A four-beat gait that should be brisk, true, and flat-footed, with good reach.
 - B. Trot: To be performed at medium speed with moderate collection. The trot should be mannerly, cadenced, balanced, and free-moving. Posting is required.
 - C. Canter: A three-beat gait that should be smooth and unhurried, with moderate collection. Horses should be straight on both leads
- 7.5.** Class to be judged on manners, performance, attitude, quality, suitability of horse to rider, and conformation.

- 7.6. Cross-entry is prohibited between English Pleasure (class 608) and Country English Pleasure (class 609).

8. Country English Pleasure

- 8.1. Class 609 – Junior or senior members riding horses or ponies
- 8.2. Horse may be shown in a snaffle, pelham, single curb, or double bridle. Light contact must be maintained at all gaits. Martingales and tiedowns are prohibited. Spurs and/or a whip or crop are optional at the rider's discretion.
- 8.3. It is imperative that the horse give the distinct appearance of being a pleasure to ride. The horse should be a safe, pleasant, and mild-mannered mount. A quiet, responsive mouth is paramount. All gaits must be performed with willingness, obvious ease, cadence, balance, and smoothness. All signs of resistance, resentment, or aggressiveness must be severely penalized.
- 8.4. Horses are to be shown at a walk, trot, and canter both ways of the ring. Horses may be asked to back.
- A. Walk: A four-beat gait that should be true, flat-footed, and ground-covering.
 - B. Trot: A two-beat gait that should be balanced, relaxed, and easy-going with elasticity and freedom of movement. High action **MUST** be penalized. Posting is required.
 - C. Canter: A three-beat gait that should be smooth, unhurried, straight, and correct on both leads.
- 8.5. It is mandatory that horses be asked to halt on the rail, stand quietly, back, and walk off on a loose rein at least one direction of the ring.
- 8.6. Class to be judged on attitude, manners, performance, quality, conformation, and suitability of horse to rider.
- 8.7. Cross-entry is prohibited between Country English Pleasure (class 609) and English Pleasure (class 608).

9. Hunter Pleasure

- 9.1. Class 610 – Junior or senior members riding horses or ponies
- 9.2. Horse must be shown in traditional Hunter-style tack and appointments. Snaffle, pelham, full (double) bridle, or kimberwick bit acceptable. Martingales, tiedowns, Saddleseat style colored browbands/cavessons, and/or figure eight, drop, or flash nosebands are not permitted. Direct but light contact must be maintained at all gaits. Spurs and/or a crop are optional at the rider's discretion.
- 9.3. It is imperative that the horse give the distinct appearance of being a pleasure to ride and display a pleasurable and relaxed attitude. The Hunter Pleasure horse should be shown in a longer, more rectangular frame than the Country English Pleasure horse, with the neck carried lower and in a more

relaxed manner, with less arch in the neck and less flexion at the poll. The stride at every gait should be long, ground-covering, and efficient. A stride that is short, high, and round is NOT appropriate. Horses that are, for more than a few strides, high headed, ridden on a draped rein, not in an appropriate frame, on the forehand, short-strided, or behind the vertical must be severely penalized.

- 9.4.** Horses are to be shown at a walk, trot, canter, and hand gallop both directions of the ring. All horses are to stand quietly and back readily.
- A. Walk: A four-beat gait that should be straight, true, and flat-footed. The walk should be regular and unconstrained, with good reach.
 - B. Trot: A two-beat gait that is straight and regular. The trot should be mannerly, cadenced, and balanced. To be performed at a medium speed with a free moving, long, ground-covering, efficient stride that is not short, high, round, or choppy. Rider to post the trot.
 - C. Canter: A three-beat gait that should be even, smooth, unhurried, correct, and straight on both leads.
 - D. Hand gallop: The hand gallop is performed with a long, free, ground-covering stride. The amount of ground covered may vary between horses due to differences in natural length of stride. A decided lengthening of stride from the canter should be shown while the horse remains controlled, mannerly, correct, and straight on both leads.
- 9.5.** Class to be judged on manners, performance, suitability as a Hunter, quality, and conformation.

10. Hunt Seat Equitation

- 10.1.** Class 611 – Junior and senior members riding horses or ponies
- 10.2.** See Hunter Division rules and rules for Hunter Pleasure (class 610) for tack, attire, and class requirements.
- 10.3.** Horses are to be shown at the walk, trot, and canter both direction of the ring. Judge, at his/her discretion, may require additional testing to determine class placings.

11. Western Pleasure

- 11.1.** Class 612 – Junior and senior members riding horses or ponies
- 11.2.** See Western Division rules for tack and attire guidelines.
Junior horses (5 yrs. old and younger) may be shown in a snaffle or bosal with two hands on the reins. All other horses must be shown in a curb bit with only one hand on the reins. Light contact with the horse's mouth must be maintained at all gaits. An excessively draped rein is just as undesirable as an extremely tight rein.

- 11.3.** A good Western Pleasure horse has a comfortable, free-flowing stride of reasonable length in keeping with individual conformation. It should cover a reasonable amount of ground with little effort. Ideally, the horse should have a balanced, sweeping motion that requires no more than light contact by the rider. The head and neck serve as a balance arm and are carried in a relaxed, natural position appropriate for each individual's own conformation. Maximum credit should be given to the responsive, confident, willingly guided horse that performs the required gaits correctly and with strength and finesse.
- 11.4.** Horses are to be shown at a walk, jog, and lope in both directions of the arena. Horses should stand quietly and back readily.
- A. Walk: A four-beat gait that should be true, flat-footed, and ground-covering.
 - B. Jog: A two-beat gait that should be free, square, slow, and easy.
 - C. Lope: A true three-beat gait that should be smooth, slow, easy, and straight on both leads.
- 11.5.** Class to be judged on manners, performance, suitability of horse to rider, substance, quality, and conformation.

12. Stock Seat Equitation

- 12.1.** Class 613 – Junior and senior members riding horses or ponies
- 12.2.** See Western Division rules and rules for Western Pleasure (class 612) for tack, attire, and class requirements.
- 12.3.** Horses are to be shown at a walk, jog, and lope in both directions of the arena. Riders may be asked to perform additional testing/pattern as deemed appropriate by the judge.

Spotted Saddle Horse Division

ALL RIDERS ARE REQUIRED TO WEAR PROPERLY FITTED ASTM/SEI-CERTIFIED HELMETS WITH CHIN STRAPS PROPERLY FASTENED AT ALL TIMES WHILE MOUNTED.

1. General Rules

- 1.1. This division is designed for Spotted Saddle Horses. A solid horse with Spotted Saddle Horse breeding (sire and dam) may compete but will be judged according to Spotted Saddle Horse standards.
- 1.2. A 4-H member may exhibit both a 2-gait horse and a 3-gait horse as long as they are different horses. **The same horse may not be shown in both 2-gait and 3-gait classes.**
- 1.3. **All horses shown in this division must pass inspection with the show's DQP prior to competing. First place winners in all classes must also be inspected at the conclusion of the class. Exception: horses are not required to be inspected before or after completing the Trail classes (classes 716, 717).**

2. Equipment for Riders and Horses for Show Purposes

- 2.1. Rider's attire – It is the tradition of the show ring that riders, drivers and handlers be correctly attired for the classes in which they compete; that attendants be neatly dressed; and that horses be properly presented. The exhibitor of each entry shall conduct themselves in a sportsmanlike manner at all times. A show committee or judge shall excuse any entry or person from showing if not properly attired as shown below.
Exhibitors will show in WESTERN attire in all classes EXCEPT designated ENGLISH classes. The attire of the rider must correspond with the type of equipment used on the horse. **Exhibitors are REQUIRED to wear properly fitted and fastened ASTM/SEI approved riding helmets at all times while mounted.**

A. Correct attire for English presentation:

- (1) English riding habit.
- (2) Polished shoes or boots (worn with jodhpur tie-downs)
- (3) Jodhpur pants, clean shirt (long-sleeved) and tie
- (4) Matching vest
- (5) Gloves (optional)
- (6) English Spurs (optional)
- (7) **Properly fitted and fastened ASTM/SEI approved riding helmet.**

- B. Correct attire for Western presentation (not specifying English)
- (1) Western shirt
 - (2) Western pants and/or clean jeans
 - (3) Western boots
 - (4) Properly fitted and fastened ASTM/SEI approved riding helmet.**
 - (5) Western tie (optional)
 - (6) Western spurs (optional)
 - (7) Western chaps (optional)
 - (8) Western skirts and gauchos (optional)
 - (9) A Western dress coat or jacket will be optional.
- 2.2. Horses – All entries shall be clean, neatly trimmed, and in good flesh, presenting a healthy appearance. Horses should be outfitted in clean and appropriate tack.
- A. Correct tack for English presentation
- (1) English saddle, show, cutback or park type
 - (2) English bridle and bit
 - (3) Braids
 - (4) Breast strap (optional)
 - (5) Whip (optional)
 - (6) Prohibited equipment:
 - (a) Artificial Appliances
 - (b) Western saddles
 - (c) Side saddles
- B. Correct tack for Western presentation
- (1) Western saddle
 - (2) Western bridle
 - (3) Western saddle pad
 - (4) Western breast strap (optional)
 - (5) Western leather show halter with matching lead (silver optional)
 - (6) Prohibited equipment:
 - (a) Hackamores
 - (b) Vinyl and patent leather
 - (c) Running or standing martingales
 - (d) Tie-downs
 - (e) Braids
 - (f) Cross-chain cavesson
 - (g) Training devices such as cables, pulleys, chains, ropes, etc., which are strictly prohibited.
- 2.3. Name plates or names of horses, stables, trainers or exhibitors are prohibited on show equipment or attendant's attire (caps, shirts, jackets, etc.) in the show ring. Failure to observe this rule is cause for dismissal from the show ring of the entry in

violation or of the entry of the stable whose name is observed in the ring (except name plates on saddles).

- 2.4. In all Spotted Saddle Horse performance classes, an exhibitor may show with 1 or 2 hands, but must maintain the same “hand hold” throughout the class.
- 2.5. **Whips** – No item may be used inside or from outside the ring while showing a horse, either in performance or in model classes, except one whip per handler no longer than 4 feet, including the snapper. No lashes or appendages or any other appliances of any kind are permitted to be attached to the whip. A whip of this kind is not permitted in the warm up ring or show ring.
- 2.6. **Shoes** – Entries shall be either barefoot or plain shod with no pads or plates welded inside or onto the shoe.
 - A. The shoe may not exceed 1 1/2 inch wide by 1/2 inch thick with the exception of caulk, which must be no thicker than 1 inch, and the turnback, which shall not exceed 1 inch. The shoe cannot extend more than 1/4 inch beyond the hoof.
 - B. Hoof bands are permitted; however, they must be at least 1/2 inch from bottom of coronary band.
 - C. No additional weight shall be allowed on or in the hoof, other than the shoe and nails.
 - D. Clips – 1/2 inch beat on clip drawn from the shoe, with no welding. Limit of three clips to a shoe: one on toe and one on each side is permitted.
 - E. Barefoot horses may be shown; however, judges must disqualify lame or tenderfooted horses.
 - F. All shoe rules apply to all four feet.
- 2.7. **Bits** – Severe bits will be penalized in the final judging. Bits with shanks of more than 10 inches must be eliminated from the show ring. Shanks are measured from the top of the metal of the top ring to bottom of the metal of the bottom ring, if the ring is welded to the bridle. If the bottom ring is broken or will twist or turn, then it is not considered a part of the shank and should not be measured as such; however, the top ring will always be included in the measurement of the shank.
 - A. If the bottom ring is welded to the shank, then it shall be considered a part of the shank and the measurement should include all of the bottom ring.
 - B. If the bottom ring of the shank is “broken” so that this bottom ring will turn or twist in any way, it is not considered a part of the shank and should not be included in the shank measurement.
 - C. If the bottom ring of the shank is not broken, that is the bottom ring is welded or joined to the shank so that this bottom ring will not turn or twist, then it is a part

of the shank and must be included in the shank measurement.

D. Curb chains or straps must lie flat against the jaw and be at least 1/2-inch wide.

3. Artificial Markings and Appliances

- 3.1. Any change in color of markings other than hoof is prohibited. Only clear grooming materials are allowed on the hide and hair. Materials may be used to remove stains.
- 3.2. All artificial appliances are prohibited. No chains or action devices shall be used on any horse. Chains on the show grounds are basis for expulsion from the show grounds.
- 3.3. Gingering – The gingering of tails is prohibited and any horse suspected of having a gingered tail will be asked to leave the show ring.
- 3.4. Lubricants – The placing of lubricants and foreign substances of any kind in the pastern area is prohibited on Spotted Saddle Horses.

4. Gaits

- 4.1. Show walk – The show walk is a smooth, easy gait, smooth back end, with the horse under control and the head set. Stiff-legged front or rear leg motion and an irregular gait, especially when entering the ring, are typical of the movement of a sore horse and the judge must immediately excuse any horse exhibiting this type of motion from the ring.
- 4.2. Show gait – An increase in speed from the show walk still being under control with the head set. Head shake or nodding of the horse's head is acceptable and will not be penalized. The back end should be smooth and the rider should exhibit an easy comfortable ride. A good show gait should never sacrifice form for speed.
- 4.3. Canter/Lope – The canter or lope is basically a collected gallop. It should be smooth and naturally rolling. Excessive pumping will be penalized. A collected movement is enjoyable to ride. The horse should be under control and on the correct lead when cantering. Horses not on the correct lead will be penalized.

5. Showmanship and Grooming

5.1. Classes

- A. Class 701 – Junior members
- B. Class 702 – Senior members

5.2. Showmanship and Grooming Scorecard

5.3 To be shown in hand at halter or bridle

5.4. Judged according to 4-H Horse Project

6. Spotted Saddle Horse Mares

6.1. Class 703

6.2. To be shown in hand at halter or bridle with natural or roached mane.

6.3. To be judged on conformation, soundness, and condition.

6.4. Each entry will be shown individually.

7. Spotted Saddle Horse Geldings

7.1. Class 704

7.2. To be shown in hand at halter or bridle with natural or roached mane.

7.3. To be judged on conformation, soundness, and condition.

7.5. Each entry will be shown individually.

8. Spotted Saddle Horse Ponies

8.1. Class 705 – Mares and geldings (all ages)

8.2. To be shown in hand at halter or bridle with natural or roached mane.

8.3. To be judged on conformation, soundness, and condition.

8.4. Each entry will be shown individually.

9. Spotted Saddle Horse Western Horsemanship

9.1. Classes

A. Class 706 – Junior members, 2-gait (no lope)

B. Class 707 – Senior members, 2-gait (no lope)

C. Class 708 – Junior and senior members, 3-gait

9.2. General Information

A. Class to enter the ring at a show walk turning to the right and proceeding in that direction.

B. All horses will show at the show walk, show gait, and lope (class 708 only) each direction of the ring. Riders in class 708 who do not canter **will not be placed** regardless of number of entries.

C. Riders must always be on the correct lead while loping. When reversing to go the other direction, horses must turn away from the rail.

D. When lined up, horses are to stand quietly and back readily on command.

E. Senior riders may be asked to mount and dismount.

F. The judge may deem necessary to judge the rider's ability by having them work individually.

9.3. Rider's Position

A. Hands – In repose, arms are to be in a straight line with the body.

B. The rider should sit the saddle in a balanced, relaxed manner, with his/her back straight and shoulders even, and arms close to the body.

- C. The stirrup should be just short enough to allow the heels to be lower than the toes.
 - D. Knees should be slightly bent and weight be directly over the balls of the feet.
 - E. Body always should appear comfortable, relaxed and flexible.
 - F. Feet should be placed in the stirrups, which vary on Western saddles.
 - G. The leg must maintain contact with the horse, to give aids to the horse.
- 9.4. Riders are to be judged on seat and hands and on their ability to ride and control a horse properly. Results as shown by the performance of the horse are not to be considered more important than the method used in obtaining them. Good hands are paramount.
- 9.5. To be shown in Western tack and attire.

10. Spotted Saddle Horse Pleasure

10.1. Classes

- A. Class 709 – Junior members, 2-gait (no lope)
 - B. Class 710 – Senior members, 2-gait (no lope)
 - C. Class 711 – Junior and senior members, 3-gait
- 10.2. Horses shall enter the ring at a show walk. Horses shall be shown both directions of the ring at the show walk, show gait, and lope (class 711 only). Horses in class 711 who do not canter **will not be placed** regardless of the number of entries.
- 10.3. Horses will then reverse directions and repeat the same.
- 10.4. Horses will be asked to back when lined up.
- 10.5. While the horse is in motion, the rider's hands shall be clear of horse and saddle.
- 10.6. Western tack including a Western saddle and a Western leather bridle will be used.

11. Spotted Saddle Horse English Pleasure

11.1. Classes

- A. Class 712 – Junior members, 2-gait (no canter)
 - B. Class 713 – Senior members, 2-gait (no canter)
 - C. Class 714 – Junior and senior members, 3-gait
- 11.2. Class procedure:
- A. Horses shall enter the ring at a show walk. Horses will be shown both directions of the ring at the show walk, show gait, and canter (class 714 only). Horses in class 714 who do not canter **will not be placed** regardless of the number of entries.
 - B. Horses shall be worked both ways of the ring.
 - C. Horses are to back easily and stand quietly.
 - D. Workouts may be held.

- E. English tack and attire are mandatory in this class. Snap brim or derby hats may be worn at the option of the exhibitor. Neatness and taste in attire is encouraged and should be a consideration of the judge in the final judging.
- F. Whips or crops not to exceed 4 feet are permitted in English Pleasure.

Dressage

Dressage will be its own division. Points will NO LONGER be assigned in the hunter division.

ALL RIDERS ARE REQUIRED TO WEAR PROPERLY FITTED ASTM/SEI-CERTIFIED HELMETS WITH CHIN STRAPS PROPERLY FASTENED AT ALL TIMES WHILE MOUNTED.

1. Classes

May enter only one class

- A. Class 901 – Junior and Senior Members (introductory level)
- B. Class 902 – Junior members (training level)
- C. Class 903 – Junior high members (training level)
- D. Class 904 – Senior members (training level)

2. Object and General Principles

The object of dressage is the harmonious development of the physique and ability of the horse. The result is a horse that is more supple, calm, loose and flexible, but also confident, attentive and alert, thus developing perfect union between horse and rider.

3. Appointments

3.1. Personal

- A. Suitable attire would include, but would not be limited to, a short riding coat of a dark color, white shirt, choker or stock tie, white or light colored breeches or jodhpurs, tall boots or paddock boots.
- B. Clothing must be neat, clean and appropriate for hunter or dressage classes.
- C. **Exhibitors are REQUIRED to wear properly fitted and fastened ASTM/SEI approved riding helmets at all times while mounted.** Blunt (unrowelled) spurs and a whip that does not exceed 43.3 inches including lash are allowed.
- D. Gloves are preferred.

3.2. Tack

- A. Horses are to be ridden in a snaffle bit (meeting USEF guidelines), with or without a drop, flash, or figure-eight noseband.
- B. Tack may be inspected prior to each ride.
- C. Martingales are not allowed.
- D. Any English type saddle may be used (i.e., dressage, forward seat, flat or cutback).

- E. No curb bits of any fashion will be allowed, including Kimberwick. All bits must be smooth without corkscrew or twisted wire. Roller bits are prohibited.

4. The Gaits and Movements

4.1. Halt

- A. Horse stands obediently quiet with equal weight on all four legs.
- B. The horse should maintain a soft contact with the rider without allowing its poll to drop below its withers nor its nose to fall behind the vertical.

4.2. Working Walk – A marching four-beat rhythm on light contact with the rider.

4.3. Free Walk on a Long Rein

- A. A four-beat rhythm with the horse stretching his topline and stride.
- B. The rider still maintains contact with the horse but the horse must stretch its nose ahead of the vertical.

4.4. Working Trot – A forward two-beat rhythm that maintains a consistent tempo while remaining on the bit.

4.5. Working Canter – A forward three-beat rhythm with a quiet consistent tempo while remaining on the bit.

5. Tests

5.1. Tests for the current year will be announced at an appropriate time.

5.2. Times will be scheduled approximately seven minutes apart.

5.3. Rider may begin schooling around the dressage arena when the rider before him/her has received a final salute from the judge and begins to exit the arena.

5.4. Upon audible signal (whistle or bell) from the judge, the competitor has 45 seconds to enter the dressage arena.

5.5. The dressage tests may be called by someone standing behind the letter E or B, or else the test may be ridden from memory.

- A. Should a rider go off course, the judge will sound an audible sound.
- B. The rider should stop and allow the judge to instruct him/her how to proceed. The rider then proceeds from memory or the caller starts calling the test from the point instructed by the judge.
- C. Being off course constitutes an error. However, if the caller aids the rider in any fashion other than calling the test, the rider is eliminated.
- D. Errors and points
 - (1) 1st error – 2 points
 - (2) 2nd error – 4 points
 - (3) 3rd error – elimination

6. Elimination

- 6.1. Automatic elimination occurs if the rider fails to enter the dressage arena within 45 seconds of the judge's audible signal.
- 6.2. All four of the horse's feet leave the arena after the test has begun.
- 6.3. Unauthorized assistance, obvious lameness or use of illegal equipment.

7. Scoring

10 Excellent	5 Sufficient
9 Very Good	4 Insufficient
8 Good	3 Fairly Badly
7 Fairly Good	2 Bad
6 Satisfactory	1 Very Bad
0 Not performed	

8. Schedules

- 8.1. A schedule denoting the time an exhibitor must perform the dressage class will be available and posted at office at the Tennessee State 4-H Horse Championships.
- 8.2. An exhibitor may not change his/her scheduled time of performance.

9. Arena

A small or large dressage arena may be used. The letters set around the arena are placed as pictured below.

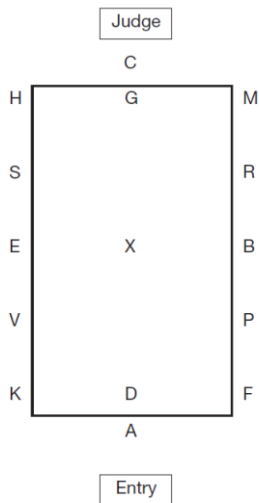

Ranch Horse Division

Horses may NOT cross enter into Western division classes, exception Western Dressage.

ALL RIDERS ARE REQUIRED TO WEAR PROPERLY FITTED ASTM/SEI-CERTIFIED HELMETS WITH CHIN STRAPS PROPERLY FASTENED AT ALL TIMES WHILE MOUNTED.

1. Tack and Attire

- 1.1. Working Western attire required for all classes: long-sleeved shirt, cowboy hat or helmet, and boots. Chaps and spurs optional. **Exhibitors are REQUIRED to wear properly fitted and fastened ASTM/SEI approved riding helmets at all times while mounted.** Cowboy hats are acceptable in halter and showmanship classes.
- 1.2. Plain attire suitable for ranch work is desired; flashy show-type attire is discouraged and will be penalized by the judge.
- 1.3. Western working tack should be used. Silver conchos are accepted, but excessive silver on tack is discouraged and will be penalized by the judge.
- 1.4. **No gag bits or twisted wire mouth pieces (smaller than 3/8") are allowed.**

2. Classes

- 2.1. Showmanship
 - A. Class 801 – Junior members
 - B. Class 802 – Junior high members
 - C. Class 803 – Senior members
- 2.2. Conformation
 - A. Class 804 – Mares (horses – all ages)
 - B. Class 805 – Geldings (horses – all ages)
- 2.3. Ranch Riding
 - A. Class 806 – Junior members
 - B. Class 807 – Junior high members
 - C. Class 808 – Senior members
- 2.4. Ranch Horsemanship
 - A. Class 809 – Junior members
 - B. Class 810 – Junior high members
 - C. Class 811 – Senior members
- 2.5. Trail
 - A. Class 812 – Junior members
 - B. Class 813 – Junior high members
 - C. Class 814 – Senior members
- 2.6. Ranch Boxing
 - A. Class 815 – Junior and Senior members

2.7. Ranch Cutting

A. Class 816 – Junior and Senior members

2.8. Ranch Reining

A. Class 817 – Junior members

B. Class 818 – Senior Members

3. Ranch Riding

3.1. Horses will be shown at three gaits: walk, jog, and lope. Rider will also be asked to reverse away from the rail, to stop, and to back. The judge may ask for an extended trot. Extended trot may be ridden by sitting in the saddle, posting, or standing in the stirrups.

3.2. A good ranch horse has a free-flowing stride of reasonable length (in keeping with his conformation) and covers a reasonable amount of ground with little effort. The motion should be balanced and flowing, with the head carried in a natural position (in keeping with the horse's conformation). The horse should be shown on a reasonably relaxed rein but with light contact and control. Responsive, smooth transitions should be shown when changing gaits.

3.3. The walk and jog should be free-moving and void of peggy, short-strided motion. The lope should be a definite three-beat gait, performed on the proper lead and showing good use of the hindquarters.

3.4. Horse's expression should be alert and mannerly, without the appearance of a dull, sullen, lethargic, drawn, or overly tired attitude. Maximum credit will be given to the flowing, balanced, and willing horse that gives the appearance of being fit, alert, and a pleasure to ride.

3.5. Horses 6 years of age and older must be ridden in a curb bit and shown with one hand. Horses 5 years of age and younger may be shown 2-handed in a snaffle bit or bosal.

3.6. Credits:

A) Natural, ground-covering gaits

B) Consistency at all gaits

C) Smooth upward and downward transitions

D) Working off hindquarters when turning

E) Working on reasonably loose rein without excessive cueing to maintain moderate pace

3.7. Faults to be penalized according to severity:

A) Lack of ground-covering gait

B) Excessive speed or slowness of gait

C) Wrong lead

D) Failure to make upward or downward transition when called for

E) Opening mouth excessively

F) Stumbling

- G) Head carried with tips of ears lower than withers for less than 3 strides

4. Ranch Horsemanship

4.1. Seat and hands

- A) Exhibitor will be judged on seat, hands, ability to control and show horse, and suitability of horse to rider.
Results as shown by performance of horse are not to be considered more important than the method used by the rider to obtain them.
- B) Upper arms to be in a straight line with body; hand(s) holding reins should be bent at the elbow. Only one hand on the reins may be used on horses shown in a curb bit. If showing a horse (5 years of age or younger) in a snaffle or bosal, two hands may be used to hold the reins.
- C) Exhibitor should sit in the saddle either with legs hanging straight and slightly forward to the stirrups or with knees bent slightly and weight directly over the balls of the feet. In either position the stirrups should be just short enough to allow the heels to be lower than the toes. Body should always appear comfortable, with heels relaxed and flexible. Feet should be placed in stirrups with weight on the balls of the feet.
Consideration should be given to width of stirrups, which may vary on Western saddles. If stirrups are wide, foot may give the appearance of being “home” when in reality the weight is being carried properly on the ball of the foot.
- D) Exhibitor should sit the jog and not post. At the lope, rider should be close to the saddle. All movements of the horse should be governed by imperceptible use of the aids. Exaggerated shifting of the rider’s weight is not desirable.

4.2. Class routine

- A) The judge must first ask each exhibitor to work individually using a designated pattern. The pattern may include any maneuvers that are normally required in any stock horse class, such as figure eights and square stops. Individual pattern work must include all three gaits. Exhibitors must also be required to back in a straight line. It must be remembered that, above all, a stock horse is expected to respond instantly and smoothly to all aids.
- B) After each exhibitor has been worked individually, the judge may recall all exhibitors or finalists to work on the rail, or the class may be placed.

- C) Exhibitors recalled for rail work shall enter the arena at a walk and be judged on the rail at a walk, jog, and lope. They shall be worked both ways of the ring and should always be on the correct lead at the lope. The reverse is to be executed by turning away from the rail. The horse should be in perfect balance at all times, working entirely off of its haunches. The head and neck should be in a direct line with the body, with the mouth closed and the head at a natural height for the horse's conformation.

5. Ranch Boxing

- 5.1.** A versatile western stock horse must also be a cow horse. This class has been designed to demonstrate and measure a horse's ability to do cow work. This class has been developed for youth riders as an entry level working cow horse class.
- 5.2.** Holding the saddle horn is permitted in this class including the extended trot portion of the cow horse pattern.
- 5.3.** The work in the cow horse class will consist of the following two parts:
- A. The rider will enter the arena and perform the cow horse pattern. After completing the cow horse pattern, the rider will face the cow end of the arena and call for a cow.
 - B. Timing will be done by the announcer starting when the cow is turned into the arena. The rider will have 1 minute to work the cow. At 1 minute, the announcer will call time.
 - C. The judge may blow a whistle at anytime for the contestant to cease work for safety reasons. Judge will give credit for what they have seen.
- 5.4. Part One: Pattern**
- A. The rider shall trot into the arena, trot to first cone and start pattern.
 - 1. Extended Trot to second cone; Stop; Back two steps; Rollback to right
 - 2. Extended Trot back to first cone; Stop; Back two steps; Rollback to left
 - 3. Lope to second cone; Stop; Rollback to right
 - 4. Lope to first cone; Stop; Rollback to left
 - 5. Lope to center; Stop, Back; Pivot 90 degrees toward cattle and call for cow to be worked.
 - B. Markers: Marker placement shall be a minimum of 20 ft from the wall.

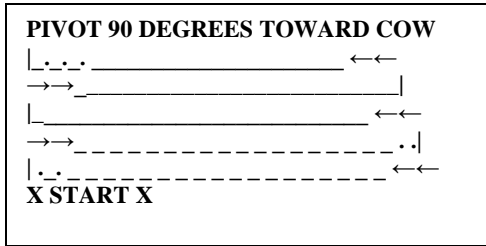

5.5. Part Two: Boxing the Cow

- A. The rider shall signal for their cow to be turned into the arena. Upon entry into the arena, the cow shall be controlled on the entry end of the arena for one minute to demonstrate the horse's ability to "hold" the cow.
- B. If the cow does not immediately challenge the horse, the rider shall aggressively move in on the cow to demonstrate his horse's ability to drive and block the cow on the entry fence.

6. Ranch Cutting

6.1 Class

- A. Class 316 Junior/Senior Ranch Cutting
- B. This class is designed to show a horse's ability to separate a cow from the herd, hold that cow away from herd, then drive that cow away from herd and to pen it. This class is to be judged on the horses natural cow ability agility and to respond softly to the rider's cues to help rein horse into position to hold cow from herd, on the way to pen and to pen cow. Horse should display softness of handle and quietness in herd. Horse and Rider should work as a team, seeming effortless to work together.

6.2 Class Routine

- A. Settling of the herd is permissible by anyone but the first entry of the class.
- B. There is a two and one half (2½) minute time limit.
- C. The number of cattle to cut in the two and one-half (2½) minute time limit.
- D. Time will begin when a rider crosses a timeline just prior to entering the herd (minimum of ten head). The rider will then quietly separate one cow from the herd and work the cow, with the exhibitor and horse showing their ability to keep the cow from the herd. Upon working completion the cow shall be driven to the opposite end of the arena and penned.
- E. A whistle will be blown at the one minute point to let exhibitor know that one and one half minutes remain to

complete the run. A contestant will be disqualified if he fails to pen the cow at the end of 2½ minutes, if the cow returns to the herd after it has been clearly separated from the herd or if cow crosses back over the time/foul line when attempting to be penned.

- F. The contestant may have up to four helpers during the cutting portion - two turn back riders and two herd holders. The helpers may not assist the contestant in penning the cow.
- G. The pen shall be placed on the side of the arena two-thirds of the way down the arena from the herd. Cow is not considered penned until the horse enters the wing area of the pen and whistle is blown. Show management may use either a 10' to 20' wing when constructing the pen.
- H. Horse will not be penalized for reining during cutting portion but should respond softly to rider's cues, showing willingness to exhibitor's directions as well as to display horse's natural cow ability in controlling and driving the cow.
- I. Show management may supply two herd holders and two turn back riders, or exhibitors may supply their own helpers. If an exhibitor is a herd holder or turn back rider, he/she may use the horse they are competing on, or use a different horse. All turn back riders and herd holders must have proper western attire. Failure to do so will result in disqualification of entry.
- J. Whistles and/or Horns to be blown at:
 - 1. One minute mark
 - 2. Cow crosses back over time line after attempting to pen
 - 3. Losing the cow back to the herd
 - 4. 2½ minute at end of time
 - 5. Completion of Run (judge's discretion)** It is the exhibitor's responsibility to keep engaging the cow until judge's whistle is blown.

6.3 Penalties

- A. One Point Penalties:
 - 1. Loss of working advantage by more than 1 horse length
 - 2. Gaping mouth when reined
 - 3. Excessive spurring or cuing
 - 4. Working out of position
 - 5. Toe, foot or stirrup on the shoulder
- B. Three Point Penalties
 - 1. Spurring in shoulder
 - 2. Cattle picked up or scattered

3. Pawing or biting cattle
 4. Back fence
 5. Two hands on reins except when exhibiting a junior horse in either a snaffle bit or hackamore (bosal)
- C. Five Point Penalties
1. Excessive help by turn back riders / per incident
- D. 0 Score
1. Illegal equipment
 2. Excessive disturbance of herd to the point that exhibitor is asked to leave the arena
- 6.4 Automatic Disqualification:**
- A. Allowing cow to return to the herd after it is clearly separated or crosses back over the time/foul line after attempting to be penned. Horse turns tail to cattle or falls to ground during any portion of the run.
- 6.5 Credits:**
- A. Credit will be given to those horses who demonstrate excellence in their herd work, driving and setting up the cow to cut, working in the center of the arena, and degree of difficulty of the cow drawn, within 2½ (two and a half) minutes. Horses will not be penalized for reining during the cutting portion, but should respond softly to rider's cues, showing willingness to exhibitors directions as well as to display horse's natural cow ability in controlling and driving the cow.
 1. Quiet in the herd and smoothness of cut
 2. Degree of difficulty
 3. Time spent working
 4. Hard work – driving a cow
 5. Driving and controlling cow – working in the center of the arena
 6. Eye appeal
 7. Softness/willingness of horse
 8. Natural Cow Ability
 9. Amount of courage
 10. Horse & Riders ability to work together
- 6.6 Scoring**
- A. 100 percent will be judged by the horse's performance and natural ability. If time and number of cattle permit, the judge may, at his discretion, award new cattle, to enable the contestant to show his horse's ability on the cow, based on the following criteria: a) The cow won't or can't run. b) The cow won't leave the end of the arena. c) The cow is blind or won't yield to the horse. d) The cow leaves the arena.

- B. Scoring will be on the basis of 0-80, with 70 denoting an average performance. Penalties are assessed per occurrence as follows:
- C. One Point Penalties will be assessed for the following:
 - 1. (Miss) losing working advantage
 - 2. Noise directed to cattle
 - 3. Toe, foot or stirrup on the shoulder of horse
 - 4. Working out of position
 - 5. Hold on too long on a cut
- D. Three Point Penalties will be assessed for the following:
 - 1. Hot quit
 - 2. Cattle picked up or scattered
 - 3. Second hand on reins
 - 4. Spur in shoulder
 - 5. Pawing or biting cattle
 - 6. Failure to make a deep cut
 - 7. Back fence
- E. Five Point Penalties will be assessed for the following:
 - 1. Horse quitting a cow
 - 2. Losing a cow
 - 3. Changing cattle after a specific commitment
 - 4. Failure to separate a single animal after leaving the herd
- F. Disqualifications
An automatic disqualification score of 0 will be given for the following:
 - 1. If horse turns tail to cattle
 - 2. If horse falls to ground
 - 3. Illegal equipment
 - 4. Leaving the work arena before time expires
 - 5. Inhumane treatment of horse
 - 6. Riding with romal or closed reins in snaffle bit/hackamore
 - 7. Failure to cut

7. Ranch Reining

7.1. Classes

- A. Class 817– Junior member
- B. Class 818 – Senior member

- 7.2. Any one of the five ARHA reining patterns may be used. One of these patterns is to be selected by show management and used by all contestants in the class.
- 7.3. Each contestant will perform the required pattern individually and separately. All horses will be judged immediately upon entering the arena and judging will cease after the last maneuver. To rein a horse is not only to guide him, but also to control his every movement. The best reined horse should be willfully guided or controlled with little or no apparent

resistance and dictated to completely. Any movement on his own must be considered a lack of control. All deviations from the exact written pattern must be considered a lack of or temporary loss of control and therefore faulted according to severity of deviation. Credit will be given for smoothness, finesse, attitude, quickness and authority in performing the various maneuvers while using controlled speed.

7.4. Scoring will be on the basis of 0 - Infinity, with 70 denoting an average performance.

A. The following will result in no score:

1. Abuse of an animal in the show arena and/or evidence that an act of abuse has occurred prior to or during the exhibition of a horse in competition.
2. Use of illegal equipment, including wire on bits, bosals or curb chains. Use of illegal bits, bosals or curb chains; when using a snaffle bit, optional curb strap is acceptable; however curb chains are not acceptable.
3. Use of tack collars, tie downs or nose bands;
4. Use of whips and/or bats;
5. Use of any attachment which alters the movement of or circulation of the tail;
6. Failure to provide horse and equipment to the appropriate judge for inspection;
7. Disrespect or misconduct by the exhibitor.
8. Closed reins are not allowed except as standard romal reins.
 - a. Excess rein may be straightened at any place a horse is allowed to be completely stopped during a pattern; rider's free hand may be used to hold romal in the normal fashion.

B. The following will result in a score of 0:

1. Use of more than index or first finger between reins
2. Use of two hands (exception in Junior or Snaffle Bit) or changing hands;
3. Improper use of the romal
4. Failure to complete pattern as written
5. Performing the maneuvers other than in specified order
6. The inclusion of maneuvers not specified, including, but not limited to:
 - a. Backing more than 2 strides
 - b. Turning more than 90 degrees

7. Equipment failures that delay completion of pattern; including dropping a rein that contacts the ground while horse is in motion.
 8. Balking or refusal of command where pattern is delayed.
 9. Running away or failing to guide where it becomes impossible to discern whether the entry is on pattern
 10. Jogging in excess of one-half (1/2) circle or one-half (1/2) the length of the arena.
 11. Over spins of more than 1/4 turn
 12. Fall to the ground by a horse or rider
- C. The following will result in a reduction of five points:
1. Spurring in front of cinch
 2. Use of either hand to instill fear or praise
 3. Holding saddle with either hand
 4. Blatant disobedience including kicking, biting, bucking, rearing and striking
- D. The following will result in a reduction of two points:
1. Breaking of gait
 2. Freeze up in spins or rollbacks
 3. On walk-in patterns, failure to stop or walk before executing a lope departure
 4. On run-in patterns, failure to be in a lope prior to the first marker
 5. If a horse does not completely pass the specified marker before initiating a stop position
- E. Starting or performing circles or figure-eights out of lead will be judged as follows:
Each time a horse is out of lead, a judge is required to deduct one point. The penalty for being out of lead is accumulative and the judge will deduct one penalty point for each quarter of the circumference of a circle or any part thereof that a horse is out of lead. A judge is required to penalize a horse one-half (1/2) point for a delayed change of lead by one stride.
- F. Deduct 1/2 point for starting circle at a jog or exiting rollbacks at a jog up to two strides.
- G. Deduct 2 points for jogging beyond two strides, but less than 1/2 circle or 1/2 the length of the arena.
- H. Deduct 1/2 point for over or under spinning up to one-eighth (1/8) of a turn.
- I. Deduct 1 point for over or under spinning from one-eighth to one-fourth (1/8 to 1/4) turn.
- J. A 1/2 point penalty deduction will be given for failure to remain a minimum of 20 feet (6 meters) from the wall or fence when approaching a stop and/or rollback.

- L. In patterns requiring a run-around, failure to be on the correct lead when rounding the end of the arena will be penalized as follows: for 1/2 the turn or less, one point; for more than 1/2 turn, two points.
- M. Penalties against the horse to be scored accordingly, but not to cause disqualification:
 - 1. Opening mouth excessively when wearing bit
 - 2. Excessive jawing, opening mouth or head raising on stop
 - 3. Lack of smooth, straight stop on haunches-bounding or side-ways stop
 - 4. Refusing to change leads
 - 5. Anticipating signals
 - 6. Stumbling
 - 7. Backing sideways
 - 8. Knocking over markers
- N. Faults against the rider to be scored accordingly, but not to cause disqualification:
 - 1. Losing stirrup
 - 2. Failure to run circles of figure eights within the markers is not considered a fault depending on arena conditions and size; however, failure to go beyond markers on rollbacks and stops is considered a fault.
- O. While horse is in motion , rider's hands shall be clear of horse and saddle.

Reining patterns on next page.

Ranch Reining Pattern #1

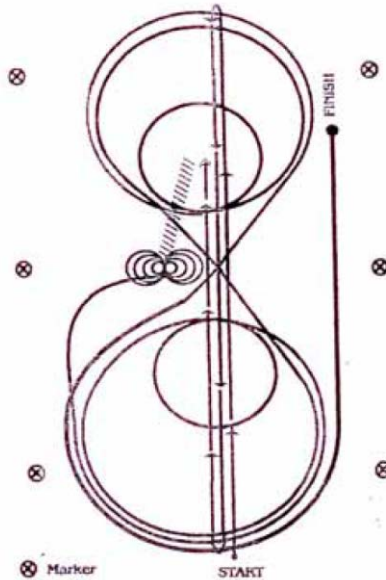

1. Run at speed to the far end of the arena past end markers and do a left rollback – no hesitation
- 2 Run to the opposite end of the arena past the end marker and do a right rollback – no hesitation
3. Run past the center marker and do a sliding stop. Back up to center of the arena or at least ten feet (3 meters). Hesitate.
4. Complete 4 spins to the right.
5. Complete 4 ¼ spins to the left so that the horse is facing left wall or fence. Hesitate.
6. Beginning on the left lead, complete 3 circles to the left, the first circle large and fast, the second small and slow, the third large and fast. Change leads in the center of arena.
7. Complete 3 circles to the right, the first circle large and fast, the second small and slow, the third large and fast. Change leads in the center of arena.
8. Begin a large fast circle to the left but do not close this circle. Run straight up the right side of the arena past the center marker and do a sliding stop at least 20 feet (6 meters) from wall or fence. Hesitate to demonstrate the completion of pattern. Rider may drop bridle to designated judge.

Ranch Reining Pattern #2

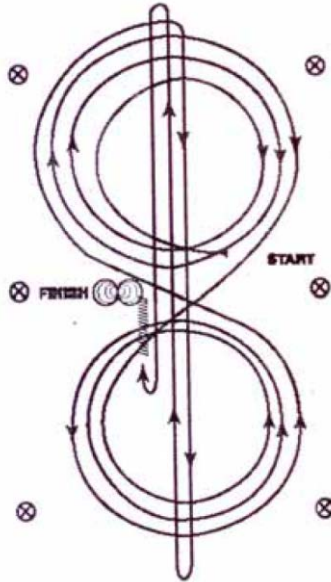

Horse must walk or stop prior to starting pattern. Beginning at the center of the arena facing the left wall or fence.

1. Beginning on the right lead, complete 3 circles to the right, the first circle small and slow, the next 2 circles large and fast. Change leads at the center of the arena.
 2. Complete 3 circles to the left, the first circle small and slow, the next 2 circles large and fast. Change leads at the center of arena.
 3. Continue around previous circle to the right. At the top of the circle, run down the middle to the far end of the arena past the end marker and do a right rollback – no hesitation.
 4. Run up the middle to the opposite end of the arena past the end marker and do a left rollback – no hesitation.
 5. Run past the enter marker and do a sliding stop. Back up to the center of the arena or at least 10 feet (3 meters). Hesitate
 6. Complete 4 spins to the right.
 7. Complete 4 spins to the left. Hesitate to demonstrate the completion of pattern.
- Rider may drop bridle to the designated judge.

Ranch Reining Pattern #3

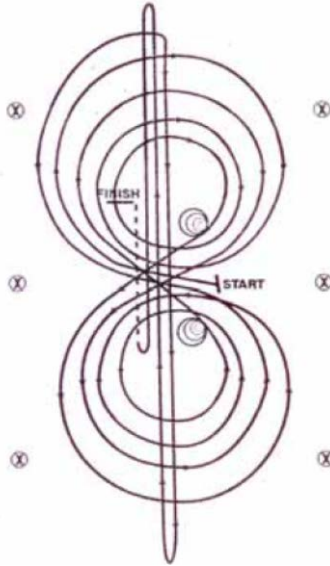

Horse must walk or stop prior to starting pattern. Beginning at the center of the arena facing the left wall or fence.

1. Beginning on the right lead, complete 3 circles to the right, the first 2 circles large and fast, the third circle small and slow. Stop at the center of the arena.
 2. Complete 4 spins to the right. Hesitate.
 3. Beginning on the left lead, complete, complete 3 circles to the left, the first 2 circles large and fast, the third circle small and slow. Stop at the center of the arena.
 4. Complete 4 spins to the left. Hesitate.
 5. Beginning on the right lead, run a large fast circle to the right, and change leads at the center of the arena, run a large fast circle to the left, and change leads at the center of the arena (figure 8).
 6. Continue around the previous circle to the right. At the top of the circle, run down the middle to the far end of the arena past the end marker and do a right rollback – no hesitation.
 7. Run up the middle to the opposite end of the arena past the end marker and do a left rollback – no hesitation.
 8. Run past the center marker and do a sliding stop. Back up to the center of the arena or at least 10 feet. Hesitate to demonstrate completion of the pattern.
- Rider may drop bridle to designated judge.

Ranch Reining Pattern #4

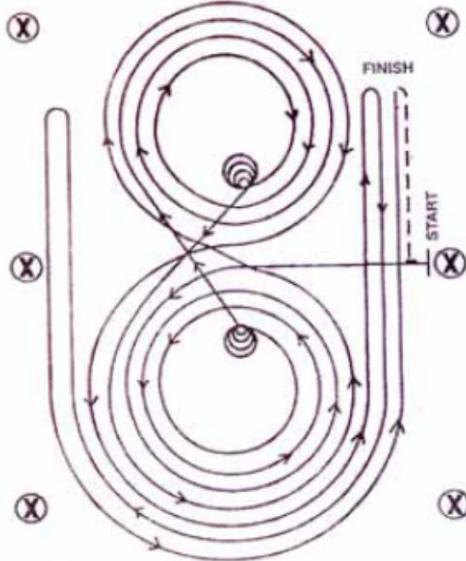

Horse must walk or stop prior to starting pattern. Beginning at the center of the arena facing the left wall or fence.

1. Beginning on the left lead, complete 3 circles to the left, the first two circles large and fast, the third circle small and slow. Stop at center or the arena.
 2. Complete 4 spins to the left. Hesitate.
 3. Beginning on the right lead, complete 3 circles to the right, the first two circles large and fast, the third small and slow. Stop at the center of the arena.
 4. Complete 4 spins to the right. Hesitate.
 5. Beginning on the left lead, run a fast circle to the left, change leads at the center of the arena, run a large fast circle to the right, change leads at the center of the arena (figure 8).
 6. Continue around the previous circle to the left but do not close the circle. Run up the right side of the arena past the center marker and do a right rollback at least 20 feet from the wall or fence – no hesitation.
 7. Continue around the previous circle but do not close this circle. Run up the left side of the arena past the center marker and do a left rollback at least 20 feet from the wall or fence – no hesitation.
 8. Continue back around previous circle but do not close this circle. Run up the right side of the arena past the center marker and do a sliding stop at least 20 feet from wall or fence. Back up at least 10 feet. Hesitate to demonstrate completion of patter.
- Rider may drop bridle to designated judge.

Ranch Reining Pattern #5

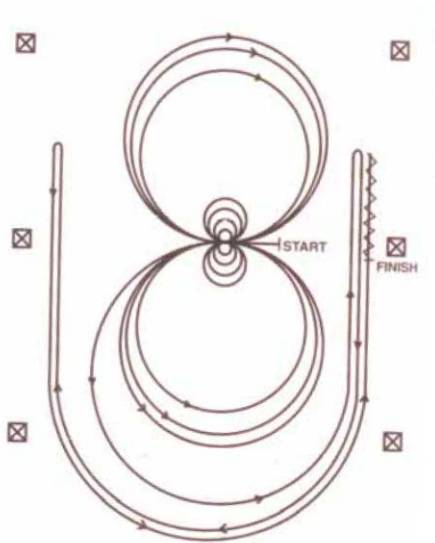

Horse may walk or trot to the center or arena. Horse Must walk or stop prior to starting pattern. Beginning at the center of the arena facing the left wall or fence.

1. Complete 4 spins to the right. Hesitate.
2. Complete 4 spins to the left. Hesitate.
3. Beginning on the left lead, complete 3 circles to the left; the first two circles large and fast, the third circle small and slow. Change leads at the center of the arena.
4. Complete three circles to the right; the first two circles large and fast, the third circle small and slow. Change leads at the center of the arena.
5. Begin a large fast circle to the left but do not close this circle. Run up the right side of the arena past the center marker and do a right rollback at least twenty feet from the wall or fence— no hesitation.
6. Continue back around previous circle but do not close this circle. Run 6. Continue back around previous circle but do not close this circle. Run up the left side of the arena past the center marker and do a left rollback at least twenty feet from the wall or fence.
7. Continue back around previous circle but do not close this circle. Run up the right side of the arena past the center marker and do a sliding stop at least twenty feet from the wall or fence. Back up at least 10 feet. Hesitate to demonstrate the completion of the pattern. Rider may drop bridle to designated judge.

8. Ranch Breakaway Roping

8.1. Class

A. Class 802 – Junior/Senior members

- 8.2.** Breakaway roping is a timed event and must be completed within one minute or a no time will be given. Common rodeo conditions and standards of calf roping apply in this contest, except the roper does not dismount or tie the calf. The roper must throw the first loop within 30 SECONDS or retire from the arena with a no score.
- 8.3.** The horse must start from behind a barrier. The length of the score line will be adjusted to fit arena conditions and shall not exceed one foot per 20 feet of arena length.
- 8.4.** A barrier judge will be designated before the contest. If the horse breaks the barrier as a result of starting too soon, the roper will receive a 10-second penalty. If the horse breaks the barrier as a result of failure of the barrier equipment, no penalty will be assessed. If the calf carries part of the barrier with it or if the roper is fouled by the barrier and the roper declares himself/herself immediately, he/she will be given a rerun. Once the calf is roped, no rerun will be given. Decisions of the barrier judge are final.
- 8.5.** A regular rope is tied to the saddle horn or swell with a breakable string. Time starts at signal of the barrier flag and stops when the official signals with a flag that the rope breaks away from the saddle as a result of a legal catch.
- 8.6.** A legal catch is defined as a loop that goes over the calf's head and draws up on any part of the body causing the rope to break from the saddle horn.
- 8.7.** Judges will rule whether a catch is legal and whether the rope breaks away as a result of a legal catch or as a result of the horse or calf stepping on the rope or similar occurrence. Contestant will be given a no time when something other than a legal catch caused the rope to break away.
- 8.8.** A piece of white cloth shall be attached to the rope at the saddle horn to signal when the rope breaks away.
- 8.9.** There is a one-minute time limit.
- 8.10.** Should the roper desire to throw a second loop, a second loop must be built. If a roper misses with two loops, the roper must retire with a no time.
- 8.11.** A roper may have assistance in the box.

4-H Horse Project Showmanship and Grooming Scorecard

Listed below are points on which youth shows are to be judged. Only the exhibitor is to be judged. The horse is merely a prop to show the ability of the exhibitor. Showmanship at halter shall be a separate class from all other halter classes. This performance class shall be judged strictly on the contestants' ability to fit and show in a halter class.

1. Appearance of Horse (40 Points)

1.1. Condition and Thriftiness (15 Points)

1.2. Grooming (15 Points)

- A. Hair coat clean, well-brushed.
- B. Mane, tail, foretop and wither tufts free of tangles and clean. Manes, tails, forelocks and wither tufts may be English- braided or manes, forelocks and wither tufts may be western-braided/banded, if the exhibitor so desires or the schedule of classes dictates due to time.
- C. Hoofs trimmed properly. If shod, shoes must fit properly and clinches should be neat.

1.3. Trimming (5 Points)

- A. Manes may be roached, but forelock and tuft over withers must be left. Manes may be long or short, banded or unbanded.
- B. Inside of ears may be clipped.
- C. Long hair on jaw, legs and pasterns should be clipped.

1.4. Tack (5 Points)

- A. Tack should be neat, clean and in good repair.
- B. Whips are prohibited in all divisions.
- C. May show in halter or bridle.

2. Appearance of Exhibitor (10 Points)

2.1. Clothes and person – neat and clean.

2.2. Suitable western or English attire clothes.

3. Showing Horse in Ring (50 Points)

3.1. Leading (15 points)

- A. Enter ring leading animal at an alert walk in a counterclockwise direction unless otherwise directed by judge. Walk on animal's left side, holding lead shank in right hand, near halter. The remaining portion of lead is held neatly and safely in left hand. Animal should lead readily at a walk or trot.
- B. The judge will call on each exhibitor to move his/her horse individually. When moving the horse, be sure that the judge gets a clear, unobstructed view of the

horse's action. Allow the horse sufficient lead so that it can move freely and in a straight line. Lead the horse from the left side the required distance, stop and turn to the right around the horse.

- C. It is mandatory that the judge post the pattern at least one hour prior to the commencing of the class; however, if the judge chooses to bring back exhibitors for consideration of final placing, the finals pattern need not be posted.

3.2. Posing (15 Points)

- A. When posing your horse, stand toward the front facing the horse, but not directly in front of the horse and always in position where you can keep your eye on the judge.
- B. Do most of the showing with lead strap. Never kick horse's leg into position.
- C. Do not crowd the exhibitor next to you when in a side by side position. Do not crowd exhibitor in front when lined up head to tail.
- D. When the judge is observing other animals, let your horse stand if posed reasonably well.
- E. Be natural; overshadowing, undue fussing and maneuvering are objectionable.

3.3. Poise, Alertness and Merits (20 Points)

- A. Keep alert and be aware of the position of the judge at all times. Don't be distracted by persons or things outside the ring.
- B. Show the animal at all times, not yourself.
- C. Respond quickly to requests from the judge and officials.
- D. Be courteous and sportsmanlike at all times.
- E. Recognize quickly and correct faults of your horse.
- F. Keep showing until the entire class has been placed and has been excused from the ring.

3.4 THE QUARTER METHOD: Suggested Guidelines of

Movement – The following guidelines are meant to serve as an illustration of movement around the horse while showing in Showmanship at Halter and are for the exhibitor's information:

- A. Imaginary lines bisect the horse into four equal parts as seen in Figure A. (Note: The quadrants will be numbered I, II, III and IV for ease of identification.) One line runs across the horse just behind the withers. The other imaginary line runs from head to tail.
- B. When the judge is in I, the handler should be in IV. As the judge moves to II, handler should move to I. When the judge moves to III, the handler moves to IV. As the judge moves up the horse to IV, the handler returns once more to I.

C. This method is based on safety as the handler can keep the horse's hindquarters from swinging toward the judge should the horse become fractious.

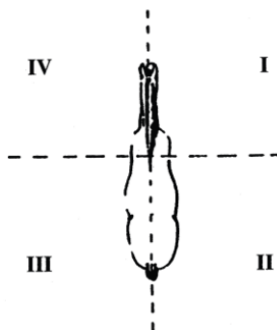

Figure A

State Communications Contests

1. Eligibility

Senior 4-H members (9th- to 12th-graders) will be eligible to participate in these activities. Members **MAY NOT** compete in a contest in which they have previously won **FIRST** place. Any 4-H member who competes in the communications contest at the Eastern National 4-H Horse Roundup **will not** be eligible to compete in that same contest at the state level.

Contestants can only enter ONE state communications contest.

2. Horse Public Speaking Contest General Contest Rules

- 2.1. Subject must pertain to the horse industry. Speeches not appropriately related to the horse industry can be disqualified at the discretion of the judge(s)
- 2.2. No visual aids may be used.
- 2.3. Contestants may use notes. However, excessive use of notes may be counted against the contestant. This will be at the discretion of the judge(s).
- 2.4. A public address system will not be used during the contest, but a lectern will be provided.
- 2.5. During the event, the contestants may introduce themselves by name, state and speech topic.
- 2.6. Speeches should be seven to 10 minutes in length. Three points will be deducted from the total score on each judge's score sheet for every minute (or fraction of a minute) under seven minutes or over 10 minutes.
- 2.7. Contestants should cite their major reference after the conclusions of their speech. This time will not be counted in the allotted time.
- 2.8. After the speech is finished, judges may question the contestant. Each judge shall ask each contestant a minimum of one question. Question time will not be counted in the allotted time. Contestants should repeat the question, then answer it.
- 2.9. Contestant order will be determined by a random drawing and at the coaches' meeting.
- 2.10. Ties will be broken first by the judges' accumulated delivery score, second by the judges' accumulated organization score and third on content and accuracy scores.

3. Scoring of Speech

3.1. Introduction (10 Points)

- A. Did the introduction serve to create interest in the subject?
- B. Was the introduction short and to the point?

3.2. Organization (15 Points)

- A. Were the main points easy to follow?
- B. Were the main points arranged in the best order?
- C. Were the sentences short and easy to understand?
- D. Was the speech interesting?

3.3. Content and Accuracy (20 Points)

- A. Were the facts and information accurate?
- B. Was there enough information concerning the subject?
- C. Was credit given to the sources of information, if appropriate?
- D. Was the content appropriately related to the horse industry?

3.4. Stage Presence (15 Points)

- A. Was the speaker neat and appropriately dressed?
- B. Did the speaker talk directly to and look at the audience?
- C. Was the speaker's posture erect, but not stiff?
- D. Did the speaker refrain from leaning on the lectern?
- E. Did the speaker seem relaxed and at ease?

3.5. Delivery (20 Points)

- A. Did the speaker have appropriate voice control?
- B. Were all the words pronounced correctly?
- C. Did the speaker's facial expressions reflect the mood of the speech?
- D. If notes were used, was it done without distracting from the speech?
- E. Did the speaker seem to choose words at the time they were spoken as opposed to a memorized or ready-type delivery?

3.6. General (10 Points)

- A. Did the speaker convey to the audience a sense of wanting to communicate?
- B. Did the speech reflect the thoughts and personality of the speaker?

3.7. Conclusion (10 Points)

- A. Was the conclusion short and interesting?
- B. Did the conclusion properly wrap up the speech?
- C. Could the speaker handle questions easily?

4. State Horse Individual Presentation Contest General Contest Rules

- 4.1.** The subject must pertain to the horse industry. Presentations not appropriately related to the horse industry can be disqualified at the discretion of the judge(s).
- 4.2.** This may be a demonstration or an illustrated presentation. No live animals may be used.
- 4.3.** Contestants may use notes. However, excessive use of notes may be counted against the contestant. This will be at the discretion of the judge(s).

- 4.4. A public address system will not be used during the contest.
- 4.5. Contestants must supply their own easels, but tables will be available.
- 4.6. Creative audiovisual aids may be used, but the contestant must be involved in making or designing them.
- 4.7. During the contest, the contestants may introduce themselves by name, state and presentation topic.
- 4.8. Presentations should be 9-12 minutes in length. Three points will be deducted from the total score on each judge's score card for every minute (or fraction of a minute) under nine minutes or over 12 minutes.
- 4.9. Contestants should cite their major references after the conclusion of their presentation. This will not be counted in the allotted time.
- 4.10. Following the presentation, judges may question the contestant. Each judge shall ask each contestant a minimum of one question. Question time will not be counted in the allotted time. Contestants should repeat the question, then answer it.
- 4.11. Contestant order will be determined by a random drawing and will be announced before the start of the contest.
- 4.12. Ties will be broken first by the judges' accumulated delivery score, second by the judges accumulated organization score and third on content and accuracy score.
- 4.13. Judges will consider the questions listed under each section.

5. Scoring the Presentation Contest

5.1. Introduction (10 Points)

- A. Did the introduction serve to create interest in the subject?
- B. Was the introduction short and to the point?

5.2. Organization (25 Points)

- A. Was only one main idea demonstrated or presented?
- B. Did the discussion relate directly to each step as it was shown?
- C. Was each step shown just as it should be done in an actual situation or was an explanation given for any discrepancies?
- D. Could the audience see each step?
- E. Were the materials and equipment carefully selected, neatly arranged and well organized?
- F. Were charts and posters used if and when they were needed?
- G. Were the key points for each step stressed?

5.3. Content and Accuracy (25 Points)

- A. Were the facts and information presented accurate?
- B. Was there enough information presented about the subject?
- C. Were approved practices used?

- D. Was credit given to the sources of information, if appropriate?
 - E. Was the content appropriately related to the horse industry?
- 5.4. Stage Presence (10 Points)**
- A. Was the presenter neat and appropriately dressed for the subject of the demonstration?
 - B. Did the presenter speak directly to and look at the audience?
 - C. Was the presenter too fast or too slow?
- 5.5. Delivery (15 Points)**
- A. Did the presenter appear to enjoy giving a demonstration?
 - B. Did the presenter have good voice control?
 - C. Were all words pronounced correctly?
 - D. If notes were used, was it done without distracting from the presentation?
 - E. Did the presenter seem to choose words at the time they were spoken as opposed to a memorized presentation?
- 5.6. Effect on the Audience (5 Points)**
- A. Did the audience show an interest in the presentation?
 - B. Could the audience go home and carry out the idea?
- 5.7. Summary (10 Points)**
- A. Was the summary short and interesting?
 - B. Were the key points briefly reviewed?
 - C. Did the summary properly wrap up the presentation?
 - D. Could the presenter handle questions easily?

6. State Horse Team Presentation Contest General Contest Rules

- 6.1.** The subject must pertain to the horse industry. Presentations not appropriately related to the horse industry can be disqualified at the discretion of the judge(s).
- 6.2.** This may be a demonstration or an illustrated presentation. No live animals may be used.
- 6.3.** Contestants may use notes. However, excessive use of notes may be counted against the contestant. This will be at the discretion of the judge(s).
- 6.4.** A public address system will not be used during the contest.
- 6.5.** Participants must supply their own props. Tables will be available for contestants.
- 6.6.** Creative audiovisual aids may be used, but the contestants must be involved in making or designing them.
- 6.7.** During the contest, the contestants may introduce themselves by name, state and presentation topic.
- 6.8.** Presentations should be 10 to 15 minutes in length. Three points will be deducted from the total score on each judge's score card

for every minute (or fraction of minute) under 10 minutes or over 15 minutes.

- 6.9. Contestants should cite their major references after the conclusion of their presentation. This will not be counted in the allotted time.
- 6.10. At the end of the presentation, judges may question the team members. Each judge shall ask each team a minimum of one question. Question time will not be counted in the allotted time. Contestants should repeat the question, then answer it.
- 6.11. Contestant order will be determined by a random drawing and will be announced at the specialist meeting.
- 6.12. Ties will be broken first by the judges' accumulated delivery score, second by the judges accumulated organization score and third on content and accuracy score.

7. Scoring the Team Demonstration

7.1. Introduction (10 Points)

- A. Did the introduction serve to create interest in the subject?
- B. Was the introduction short and to the point?

7.2. Organization (25 Points)

- A. Was only one main idea presented?
- B. Did the discussion relate directly to each step as it was shown?
- C. Was each step shown just as it should be done in an actual situation or was an explanation given for any discrepancies?
- D. Could the audience see each step?
- E. Were the materials and equipment carefully selected, neatly arranged and well organized?
- F. Were charts and posters used if and when they were needed?
- G. Were the key points for each step stressed?

7.3. Content and Accuracy (25 Points)

- A. Were the facts and information presented accurate?
- B. Was there enough information presented about the subject?
- C. Were approved practices used?
- D. Was credit given to the sources of information, if appropriate?
- E. Was the content appropriately related to the horse industry?

7.4. Stage Presence (10 Points)

- A. Were the presenters neat and appropriately dressed for the subject of the demonstration?
- B. Did the presenters speak directly to and look at the audience?
- C. Was the presentation too fast or too slow?

7.5. Delivery (15 Points)

- A. Did the presenters appear to enjoy giving a demonstration?
- B. Did the presenters have good voice control?
- C. Were all words pronounced correctly?
- D. If notes were used, was it done without distracting from the presentation?
- E. Did the presenters seem to choose words at the time they were spoken as opposed to a memorized presentation?

7.6. Effect on the Audience (5 Points)

- A. Did the audience show an interest in the presentation?
- B. Could the audience go home and carry out the idea?

7.7. Summary (10 Points)

- A. Was the summary short and interesting?
- B. Were the key points briefly reviewed?
- C. Did the summary properly wrap up the demonstration?
- D. Could the presenters handle questions easily?

Tennessee State 4-H Horse Judging Contest

1. Eligibility

The top four senior 4-H horse judging teams from each of the three regions are eligible. Previous Tennessee State 4-H Horse Judging Senior Division Champions **will not** be eligible to compete in future horse judging contests (regional or state). Any 4-H member who competes in the Horse Judging Contest at the Eastern National 4-H Horse Roundup **will not** be eligible to compete in future 4-H horse judging contests (regional or state).

2. Classes

Classes will be indicative of the varied horse population in Tennessee.

- 2.1. Halter classes can include, but are not limited to, Quarter Horses, Tennessee Walking Horses, Arabians, Hunters, Saddlebreds, and Spotted Saddle Horses.
- 2.2. Performance classes can include, but are not limited to, Western Pleasure, Hunter Under Saddle, Plantation Pleasure, Western Riding, English Pleasure, Reining, Hunter Hack, Western Horsemanship, and Hunt Seat Equitation.

3. Reasons

Oral reasons will not exceed two halter and two performance classes. A minimum of three sets of reasons will be given.

4. Out-of-State Trips

- 4.1. The first-place team will represent Tennessee at the Eastern National 4-H Horse Judging Contest in Louisville, KY.
- 4.2. The winning team will receive \$500 toward total team expenses for the Eastern National contest.
- 4.3. The first and second place team will represent Tennessee at the Southern Regional 4-H Horse Championship Judging Contest held annually in the South or Southwest. No expenses provided.
- 4.4. It is possible that lower-placing teams can represent Tennessee at other contests (Congress, AQHYA World, Paint Nationals, Arabian Nationals, etc.). However, higher-ranking teams will receive priority.

Tennessee State 4-H Horse Bowl

1. Eligibility

The top four teams in each age division from each regional contest may participate in the state contest. Previous Tennessee State 4-H Horse Bowl Senior Division Champions **will not** be eligible to compete in future horse bowl contests (regional or state). Any 4-H member who competes in the Horse Bowl Contest at the Eastern National 4-H Horse Roundup **will not** be eligible to compete in future 4-H horse bowl contests (regional or state).

2. Age divisions

There will be three age divisions:

- Junior (4th and 5th grades)
- Junior High (6th through 8th grades)
- Senior (9th through 12th grades)

3. Study material

3.1. Junior Division

- A. *Horse Industry Handbook: A Guide to Equine Care and Management* (AYHC)
- B. 1999, 2003, **2004, 2007, 2011, 2014** *Horse Industry Handbook* Updates (AYHC) *Horse Industry Handbook* Updates (AYHC)
- C. *Equine Science: Basic Knowledge for Horse People of All Ages* (Griffiths)
- D. *The Coloring Atlas of Horse Anatomy* (Kainer)
- E. **Dover Saddlery** - Apparel, tack and horse care items, for the English rider. To request a free catalog please visit DoverSaddlery.com or call toll free 1 888 234 6942
- F. **Smith Brothers** - Apparel, tack and horse care items, for the Western rider. To request a free catalog please visit SmithBrothers.com or toll free 1- 888 677 0450

3.2. Junior High Division

- A. All Junior Division sources
- B. *The Horse: 2nd Edition* (Evans et. al)

3.3. Senior Division

- A. All Junior and Junior High Division sources
- B. *Feeding and Care of the Horse: 2nd Edition* (Lewis)
- C. *Nutrient Requirements of Horses* (2007; NRC)

3.4. Knowledge Areas

- A. Juniors will be responsible for studying the following topics from all sources listed above:
 - 1. Introduction to Horse Ownership (including breeds, colors, history, etc.)
 - 2. Selection and Use (including judging, basic conformation, etc.)

3. Hoof Care
 4. Equine Health Management
 5. Tack and Equipment
 6. Nutrition and Feeding
- B. Junior High members will be responsible for studying all Junior Division topics PLUS:
1. Equine Diseases
 2. Facilities/Waste Management
- C. Senior members will be responsible for studying all Junior and Junior High Division topics PLUS:
1. Exercise Physiology
 2. Genetics
 3. Reproduction
 4. Training/Horse Behavior

4. Contest Rules

- 4.1. A team **must** consist of at least three (3) and no more than four (4) members. Three member teams will be at a disadvantage, particularly in the Senior division. A three member team **may not** compete in national competitions.
- 4.2. Team members and leaders are allowed to observe contest rounds.
- 4.3. Random drawings will determine brackets in each age division. Teams from the same county will not compete head-to-head in the first round of the contest.
- 4.4. County names must precede team names for all teams. (Example: Lamb County Black Sheep A; Crockett County Pioneers)
- 4.5. **All decisions of the judge, scorekeepers, timer, and moderator are final.**
- 4.6. Spectators, parents, and visitors may not protest any questions, answers, or procedures during the course of play. They may, however, submit in writing to the contest officials any suggestions, complaints, or protests at the conclusion of the contest. Unseemly behavior, unsportsmanlike conduct, or any actions which are generally accepted as detrimental to the contest by any person associated with a particular team (i.e. parent, agent, team member, volunteer leader, etc.) will disqualify that entire team from the contest.
- 4.7. There will be **ABSOLUTELY NO** audio or video recording of any round of the contest. Additionally, no one (including but not limited to spectators, parents, coaches, visitors, and agents) may write down questions and/or answers during the contest. The use of cell phones (including texting) is also forbidden in the contest room(s). Anyone found in violation of this rule will be removed from the contest room(s) for the duration of the contest.

4.8. There will be **NO** travel money available for the State-winning Senior Horse Bowl team to compete in the national contest. members of the champion team are eligible to compete in the national contest at their own expense.

4.9. Contest Procedure

- A) Each round will consist of 20 questions (8 one-on-one questions followed by 12 toss-up questions).
- B) One-on-one and toss-up questions are worth +10 points for correct answers and -5 points for incorrect answers. Bonus questions are worth +15 points for correct answers, with no penalty for incorrect answers.
- C) During the one-on-one questions, Player 1 from Team A competes against Player 1 from Team B, Player 2 from Team A competes against Player 2 from Team B, etc. Each player will have the opportunity to answer two one-on-one questions.
- D) In cases where a 3-member team is competing against a 4-member team:
 - 1) The 3-member team will get a bonus question after all three team members give a correct answer, while the 4-member team will get a bonus question after only three members give a correct answer.
 - 2) During the one-on-one questions, the 4-member team will have the option of either answering without buzzing in or declining to answer the question posed to the fourth member (the team member who is opposite the vacant chair on the 3-member team). A wrong answer will still be penalized; declining to answer will not be penalized.
- E) In cases where two 3-member teams are competing against one another, the rules will be the same as when two 4-member teams are competing.
- F) A “Quiz-A-Tron” will be used. The first member to “buzz” in may answer the question.
- G) The first person whose light flashes must answer the question within 10 seconds or lose 5 points. The first answer given by the contestant will be the **ONLY** answer accepted. If this answer is incorrect, the other team may have the question re-read and then answer.
- H) When a buzzer is pushed before the question is completely read, the moderator shall stop reading the question at the sound of the buzzer. If the answer given is incorrect, the other team may answer immediately or ask to hear the entire question.
- I) A bonus question will be given to a team when all members have answered a question correctly. (See

4.8.D above for exceptions.) Discussion is allowed on bonus questions only. The answer must come from the team captain, only the first answer given will be accepted, and the answer must be started within 30 seconds or no points will be awarded.

J) Ties will be broken by a short round consisting of five (5) toss-up questions.

Tennessee State 4-H Hippology Contest

1. Eligibility

The top four (4) teams in each age division from each regional contest may participate in the state contest. Previous Tennessee state-winning 4-H Hippology Senior Division teams will **not** be eligible to compete in future Hippology contests (regional or state). Any 4-H member who competes in the Hippology Contest at the Eastern National 4-H Horse Roundup **will not** be eligible to compete in future 4-H Hippology contests (regional or state).

2. General Rules

- 2.1. Teams will consist of 3 or 4 members. The top 3 individual scores will be used to compute the team score. All four team members will be eligible for individual awards.
- 2.2. There will be three age divisions: Junior (4th and 5th grades), Junior High (6th through 8th grades), and Senior (9th through 12th grades).
- 2.3. The Junior and Junior High division contests will consist of three separate parts, while the Senior division contest will consist of five separate parts.
- 2.4. There is **NO** travel money available for the Champion Senior division team to compete at national-level contests. The Senior division Champion team is eligible to compete at national-level contests at its own expense.
- 2.5. Spectators, parents, and visitors may not protest any question, answer, or procedure during the course of the competition. They may, however, submit in writing to the contest officials any suggestions, complaints, or protests at the conclusion of the event. Unseemly behavior, unsportsmanlike conduct, or any actions which are generally accepted as detrimental to the contest by any person association with any team (i.e. volunteer leader, agent, parent, team member, visitor, etc.) will disqualify that entire team from the contest.
- 2.6. **All decisions of the judge(s), scorekeepers, timer, and/or moderator are final.**
- 2.7. References:
 - A. Junior Division
 1. *Horse Industry Handbook: A Guide to Equine Care and Management* (AYHC)

2. 1999,2003, **2004, 2007, 2011, 2014** *Horse Industry Handbook* Updates (AYHC)
 3. ***Equine Science: Basic Knowledge for Horse People of All Ages*** (Griffiths)
 4. ***The Coloring Atlas of Horse Anatomy*** (Kainer)
 5. **Dover Saddlery** - Apparel, tack and horse care items, for the English rider. To request a free catalog please visit DoverSaddlery.com or call toll free 1 888 234 6942
 6. **Smith Brothers** - Apparel, tack and horse care items, for the Western rider. To request a free catalog please visit SmithBrothers.com or toll free 1- 888 677 0450
- B. Junior High Division
1. All Junior Division sources
 2. *The Horse: 2nd Edition* (Evans et. al)
- C. Senior Division
1. All Junior and Junior High Division sources
 2. *Feeding and Care of the Horse: 2nd Edition* (Lewis)
 3. *Nutrient Requirements of Horses* (2007; NRC)

3. Contest Procedures

3.1. Part I: Written Test

- A) Junior High/Senior divisions: 50 questions worth 2 points each (100 points total)
- B) Junior division: 35 questions worth 2 points each (70 points total)

3.2. Part II: Identification

- A) Junior High/Senior divisions: 50 questions worth 2 points each (100 points total)
- B) Junior division: 25 questions worth 2 points each (50 points total)
- C) Will consist of multiple-choice PowerPoint Slide questions covering any of these subjects:
 - 1) Feeds
 - 2) Breeds and colors
 - 3) Health
 - 4) Tack and equipment
 - 5) Anatomy and physiology
- D) Identification could include (but is not limited to):
 - 1) Parts of the horse's anatomy
 - 2) External parts (points) of the horse
 - 3) Different breeds of horses
 - 4) Different colors/patterns of horses
 - 5) Different uses of the various breeds
 - 6) Parts of a saddle (English or Western)
 - 7) Tack identification and/or use

- 8) Grains/hays for horses (I.D. and/or nutritional content)
 - 9) Protein sources for rations (I.D. and/or nutritional content)
 - 10) Various dewormers/vaccines and their uses
 - 11) Veterinary tools and equipment
 - 12) Farrier tools and equipment/horse shoes
- E) This is a section to test both knowledge and “horse sense” of the 4-H member.
- 3.3. Part III: Horse judging**
- A) Two classes of horses worth 50 points per class (100 points total)
 - B) Classes may come from videos, photographs, models, or live horses.
 - C) Halter and/or performance classes may be judged.
- 3.4. Part IV: Team stations (Senior division only)**
- A) Up to **SIX** (6) stations worth 10 points each (possible 60 points total)
 - B) Material for team stations will be similar to that tested in Part II (Identification) – See 3.2.
 - C) Teams will rotate from station to station.
- 3.5. Part V: Team problem (Senior division only)**
- A) One question/problem worth 20 points
 - B) Problems will cover practical horse management or training situations.
 - C) Teams will be given 10 minutes to discuss the question and prepare an answer.
 - D) Each team will present an answer orally to the judge in 3-5 minutes. The judge may question the team members for clarification. Each team will be asked at least one question.

UT EXTENSION
INSTITUTE OF AGRICULTURE
THE UNIVERSITY OF TENNESSEE

PB 1760 E12-4422-00-013-15

Programs in agriculture and natural resources,
4-H youth development, family and consumer sciences,
and resource development.

University of Tennessee Institute of Agriculture,
U.S. Department of Agriculture and county governments cooperating.
UT Extension provides equal opportunities in programs and employment.